

XMLB002C2C11

tlačna sklopka XMLB 2,5 bara – 2 podesiva praga – 1 C/O



Glavno

Range of product	OsiSense XM
Product or component type	Electromechanical pressure sensor
Pressure sensor type	Electromechanical pressure sensor
Device short name	XMLB
Pressure sensor size	2.5 bar
Controlled fluid	Corrosive fluid (0...160 °C)
Fluid connection type	G 1/4 (female) conforming to ISO 228
Electrical connection	1 male connector EN 175301-803-A (ex DIN43650) 4 pins
Contacts type and composition	1 C/O
Product specific application	-
Pressure switch type of operation	Regulation between 2 thresholds
Electrical circuit type	Control circuit
Scale type	Adjustable differential
Local display	With
Adjustable range of switching point on rising pressure	0.3...2.5 bar
Adjustable range of switching point on falling pressure	0.14...2.29 bar
Possible differential maximum at 1.75 bar high setting	
Maximum permissible accidental pressure	9 bar
Destruction pressure	18 bar
Pressure actuator	Diaphragm
Materials in contact with fluid	PTFE 316L stainless steel
Enclosure material	Zinc alloy
[In] rated current	3 A, B300, AC-15 (Ue = 120 V) conforming to EN/IEC 60947-5-1 1.5 A, B300, AC-15 (Ue = 240 V) conforming to EN/IEC 60947-5-1 0.1 A, R300, DC-13 (Ue = 250 V) conforming to EN/IEC 60947-5-1

Komplementarno

Possible differential minimum at low setting	0.16 bar (- 0.03 bar, + 0.05 bar)
Possible differential minimum at high setting	0.21 bar (- 0.03 bar, + 0.05 bar)
Maximum permissible pressure - per cycle	5 bar
Terminal block type	4 terminals
Operating rate	120 cyc/mn
Repeat accuracy	< 2 %
[Ui] rated insulation voltage	500 V conforming to EN/IEC 60947-1 300 V conforming to UL 508 300 V conforming to CSA C22.2 No 14
[Uimp] rated impulse withstand voltage	6 kV conforming to EN/IEC 60947-1
Auxiliary contacts operation	Snap action
Contacts material	Silver contacts
Resistance across terminals	< 25 mOhm conforming to IEC 255-7 category 3 < 25 mOhm conforming to NF C 93-050 method A

Informacije dane u ovoj dokumentaciji sadrže opće tehničke karakteristike o performansama ovdje sadržanih proizvoda. Ova dokumentacija nije namijenjena kao zamjena za niti bi se trebala koristiti za određivanje prikladnosti ili pouzdanosti predmetnih proizvoda za konkretne korisničke primjene. Svaki takav korisnik ili integrator dužan je provesti odgovarajuću i potpunu analizu rizika, procjenu i ispitivanje proizvoda u odnosu na odgovarajuću specifičnu primjenu ili uporabu istog. Niti društvo Schneider Electric Industries SAS niti bilo koje od njegovih povezanih poduzeća ili podružnica neće preuzeti obvezu ili snositi odgovornost za pogrešnu upotrebu ovdje sadržanih informacija.

Short-circuit protection	10 A cartridge fuse type gG (gl)
Mechanical durability	8000000 cycles
Setting	External
Height	113 mm
Depth	75 mm
Width	55 mm
Product weight	1.03 kg

Okolina

standards	CE EN/IEC 60947-5-1 UL 508 CSA C22.2 No 14
product certifications	BV CCC CSA LROS (Lloyds register of shipping) UL EAC
protective treatment	TC (standard version)
ambient air temperature for operation	-25...70 °C
ambient air temperature for storage	-40...70 °C
operating position	Any position
vibration resistance	4 gn (f = 30...500 Hz) conforming to IEC 60068-2-6
shock resistance	50 gn conforming to IEC 60068-2-27
electrical shock protection class	Class I conforming to IEC 1140 Class I conforming to IEC 536 Class I conforming to NF C 20-030
IP degree of protection	IP65 conforming to EN/IEC 60529

Offer Sustainability

Not Green Premium product	Not Green Premium product
Compliant - since 0928 - Schneider Electric declaration of conformity	Compliant - since 0928 - Schneider Electric declaration of conformity
Reference not containing SVHC above the threshold	Reference not containing SVHC above the threshold
Need no specific recycling operations	Need no specific recycling operations

Contractual warranty

Warranty period	18 months
-----------------	-----------

Dimensions

mm
in.

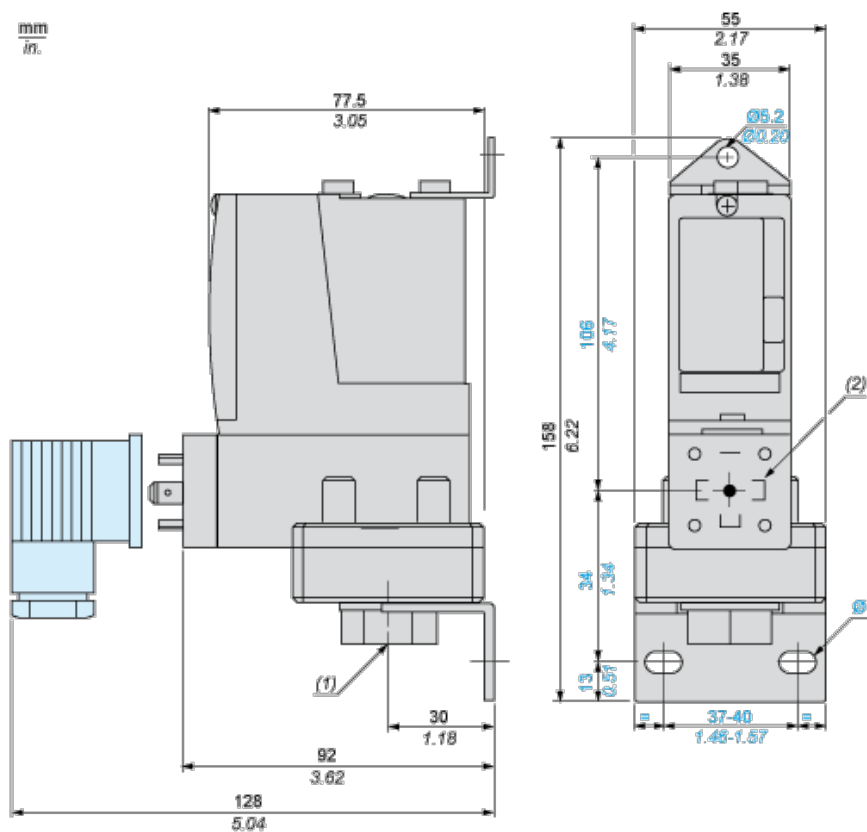

- (1) 1 fluid entry, tapped G1/4 (BSP female)
- (2) EN 175301-803-A connector
- Ø : 2 elongated holes Ø 10.2 x 5.2

Wiring Diagram

Terminal Model

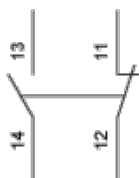

Wiring Diagram

Vacuum Switch Connector Pin View



- (1) 11 and 13
- (2) 12
- (3) 14

Operating Curves

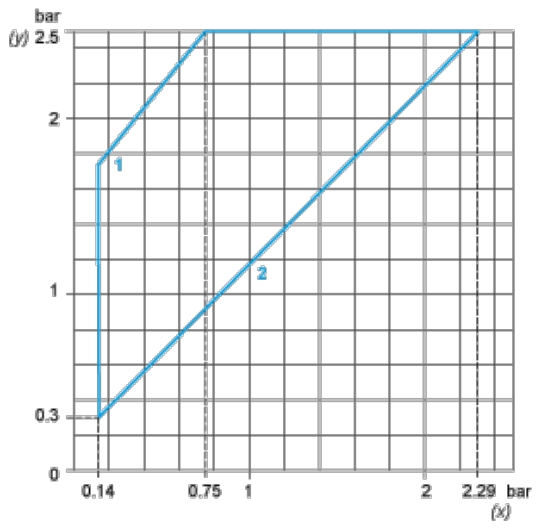

- (y) Rising pressure
- (x) Falling pressure
- 1 : Maximum differential
- 2 : Minimum differential

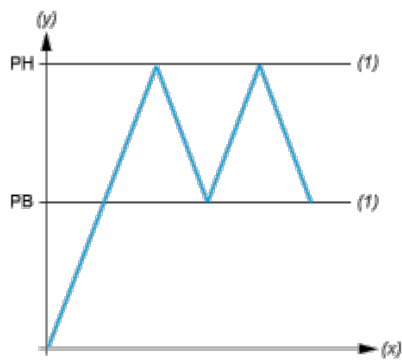

- (y) Pressure
- (x) Time
- (1) Adjustable value
- PH : High point
- PB : Below point