

TM7BDI16B

blok proširenja – TM7 – IP67 – 16 DI – 24 V DC – konektor M8



Glavno

Range of product	Modicon TM7
Product or component type	Discrete I/O expansion block
Range compatibility	Modicon LMC058 Modicon M258
Enclosure material	Plastic
Bus type	TM7 bus
[Ue] rated operational voltage	24 V DC
Input/output number	16
Input/output number of splitter box	16 I

Komplementarno

Discrete input number	16 input(s)
Discrete input voltage	24 V
Discrete input voltage type	DC
Discrete input current	7 mA
Discrete input logic	Positive
Sensor power supply	24 V, 500 mA for all channels with overload, short-circuit and reverse polarity protection
Electrical connection	1 male connector M8 - 4 ways for power IN 1 female connector M8 - 4 ways for power OUT 1 male connector M12 - B coding - 4 ways for bus IN 1 female connector M12 - B coding - 4 ways for bus OUT 16 female connectors M8 - 3 ways for sensor
Local signalling	2 LEDs for bus diagnostic 2 LEDs for sensor power supply diagnostics
Operating position	Any position
Fixing mode	By 2 screws
Product weight	0.32 kg

Okolina

standards	IEC 61131-2
product certifications	C-Tick CURus GOST-R ATEX II 3g EEx nA II T5
marking	CE
ambient air temperature for operation	-10...60 °C
ambient air temperature for storage	-25...85 °C
relative humidity	5...95 % without condensation or dripping water
pollution degree	2 conforming to IEC 60664
IP degree of protection	IP67 conforming to IEC 61131-2
operating altitude	0...2000 m
storage altitude	0...3000 m
vibration resistance	7.5 mm constant amplitude (f = 2...8 Hz) conforming to IEC 60721-3-5 Class 5M3 2 gn constant acceleration (f = 8...200 Hz) conforming to IEC 60721-3-5 Class 5M3 4 gn constant acceleration (f = 200...500 Hz) conforming to IEC 60721-3-5 Class 5M3
shock resistance	30 gn for 11 ms conforming to IEC 60721-3-5 Class 5M3

Informacije dane u ovoj dokumentaciji sadrže opće opise i/ili tehničke karakteristike o performansama ovdje sadržanih proizvoda. Ova dokumentacija nije namijenjena kao zamjena za niti bi se trebala koristiti za određivanje prikladnosti ili pouzdanosti predmetnih proizvoda za konkretne korisničke primjene. Svaki takav korisnik ili integrator dužan je provesti odgovarajuću i poplunu analizu rizika, procjenu i ispitivanje proizvoda u odnosu na odgovarajuću specifičnu primjenu ili uporabu istog. Niti društvo Schneider Electric, Industries SAS niti bilo koje od njegovih povezanih poduzeća ili podružnica neće preuzeti obvezu ili snositi odgovornost za pogrešnu upotrebu ovdje sadržanih informacija.

electromagnetic compatibility

Conducted and radiated emissions conforming to CISPR 11
Conducted RF disturbances conforming to EN/IEC 61000-4-6
Electrostatic discharge immunity test (level: 4 kV - on contact) conforming to EN/IEC 61000-4-2
Electrostatic discharge immunity test (level: 8 kV - in air) conforming to EN/IEC 61000-4-2
Susceptibility to electromagnetic fields (level: 1 V/m - 2...2.7 GHz) conforming to EN/IEC 61000-4-3
Susceptibility to electromagnetic fields (level: 10 V/m - 80...2000 MHz) conforming to EN/IEC 61000-4-3
Electrical fast transient/burst immunity test (level: 2 kV - power supply) conforming to EN/IEC 61000-4-4
Electrical fast transient/burst immunity test (level: 1 kV - input/output) conforming to EN/IEC 61000-4-4
Electrical fast transient/burst immunity test (level: 1 kV - shielded cable) conforming to EN/IEC 61000-4-4
1.2/50 µs shock waves immunity test (level: 0.5 kV - power supply (common mode)) conforming to EN/IEC 61000-4-5
1.2/50 µs shock waves immunity test (level: 1 kV - power supply (differential mode)) conforming to EN/IEC 61000-4-5
1.2/50 µs shock waves immunity test (level: 0.5 kV - unshielded links (common mode)) conforming to EN/IEC 61000-4-5
1.2/50 µs shock waves immunity test (level: 1 kV - unshielded links (differential mode)) conforming to EN/IEC 61000-4-5
1.2/50 µs shock waves immunity test (level: 0.5 kV - shielded links (common mode)) conforming to EN/IEC 61000-4-5
1.2/50 µs shock waves immunity test (level: 1 kV - shielded links (differential mode)) conforming to EN/IEC 61000-4-5

Offer Sustainability

Green Premium product	Green Premium product
Compliant - since 1039 - Schneider Electric declaration of conformity	Compliant - since 1039 - Schneider Electric declaration of conformity
Reference not containing SVHC above the threshold	Reference not containing SVHC above the threshold
Available	Available
Available	Available

Contractual warranty

Warranty period	18 months
-----------------	-----------

Digital Input Block

Description

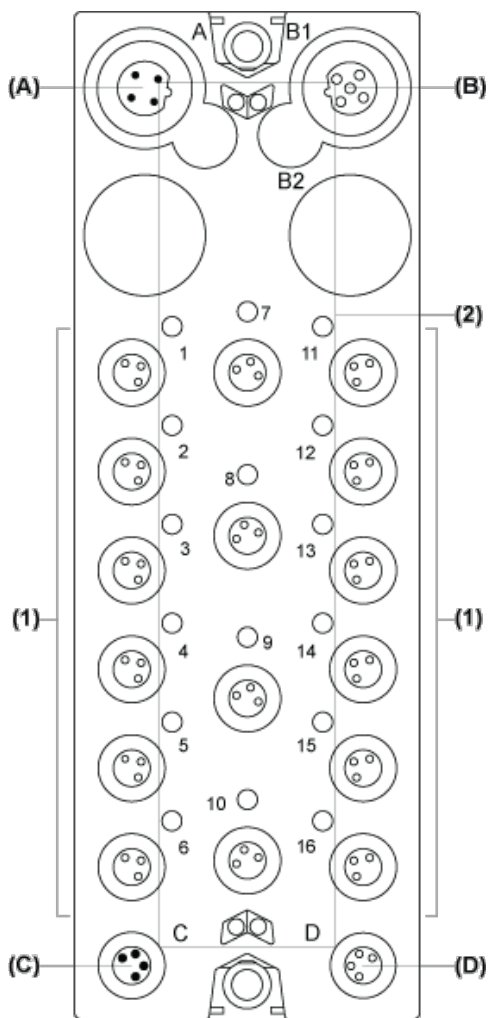

- (A) TM7 bus IN connector
- (B) TM7 bus OUT connector
- (C) 24 Vdc power IN connector
- (D) 24 Vdc power OUT connector
- (1) Input connectors
- (2) Status LEDs

Connector and Channel Assignments

Input connectors	Channel type	Channels
1	Input	I0
2	Input	I1
3	Input	I2
4	Input	I3
5	Input	I4
6	Input	I5
7	Input	I6
8	Input	I7
9	Input	I8
10	Input	I9
11	Input	I10
12	Input	I11
13	Input	I12
14	Input	I13

15	Input	I14
16	Input	I15

TM7 Block, Size 2

Dimensions

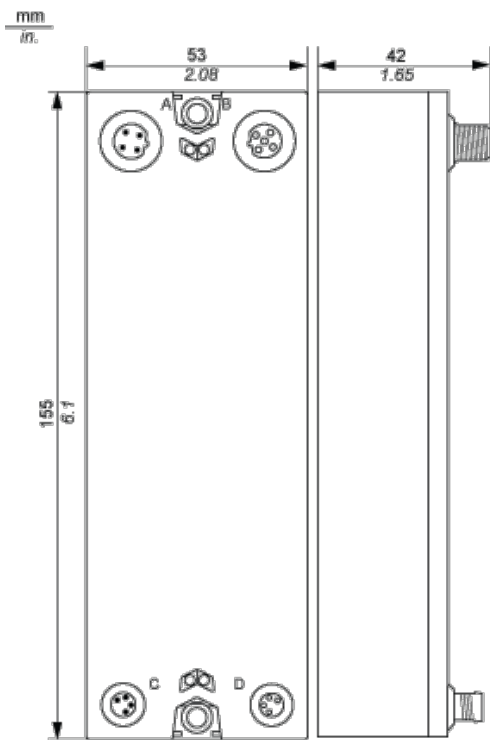

Spacing Requirements

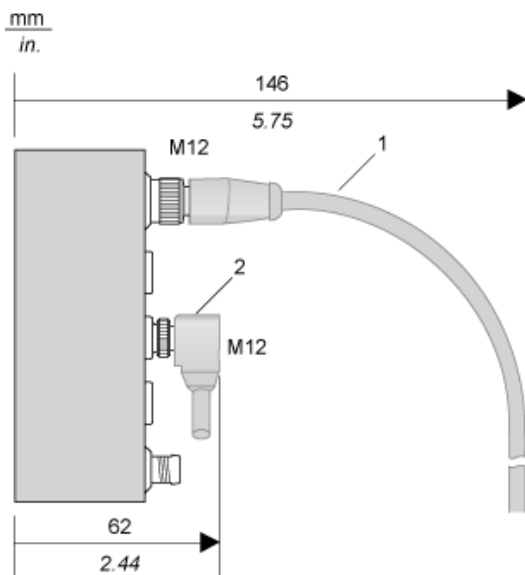

- 1 Straight cable
- 2 Elbowed cable

Installation Guidelines

TM7 Block on an Aluminium Frame

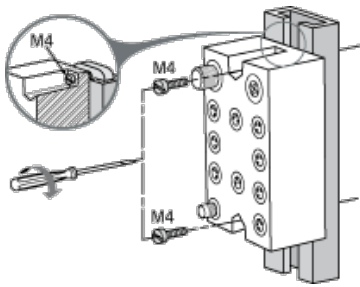

NOTE: Maximum torque to fasten the required M4 screws is 0.6 N.m (5.3 lbf-in).

TM7 Block on a DIN Rail

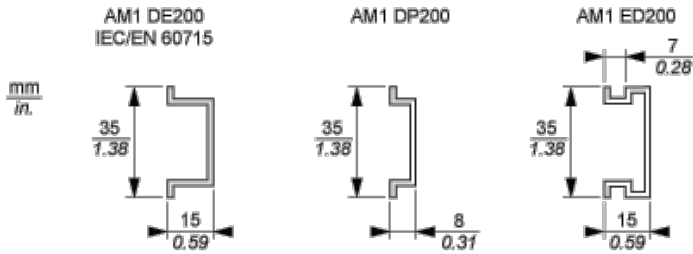

NOTE: Only size 1 (smallest) blocks can be installed on DIN rail with the TM7ACMP mounting plate.

TM7 Block Directly on the Machine

Drilling template of the block:

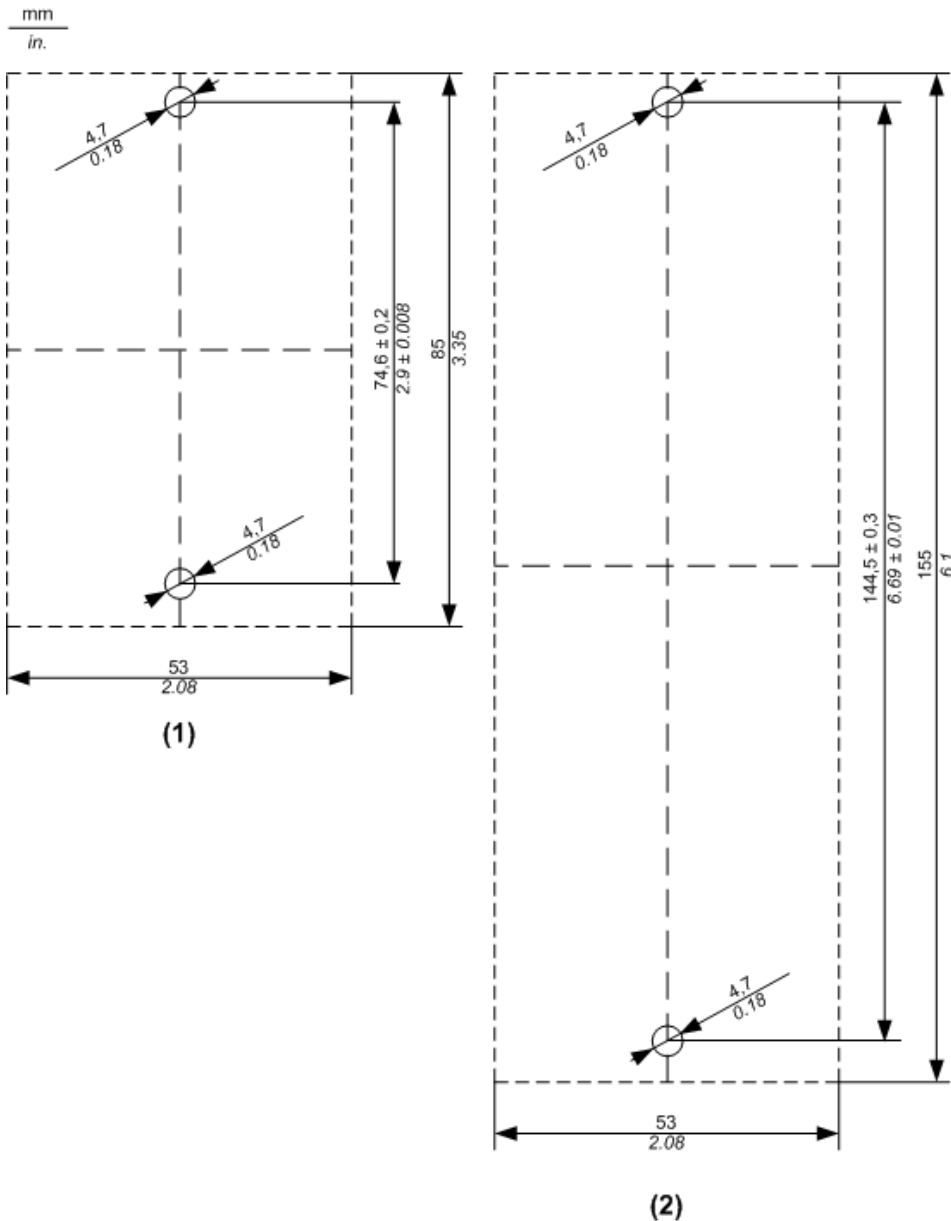

- (1) Size 1
- (2) Size 2

The thickness of the base plate should be taken into consideration when defining the screw length.

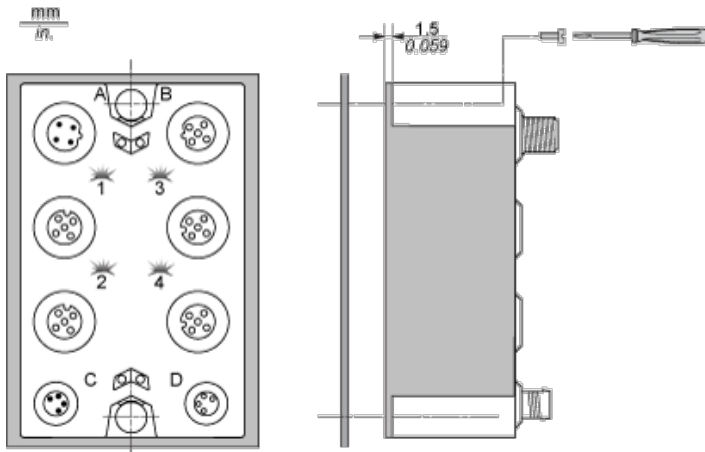

NOTE: Maximum torque to fasten the required M4 screws is 0.6 N.m (5.3 lbf-in).

Wiring Diagram

Pin Assignments for Input Connectors

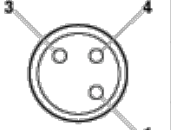
Connection	Pin	M8 Input
	1	24 Vdc sensor supply
	3	0 Vdc
	4	DI: input signal

Wiring the Power Supply

When you provide power to a TM7 I/O block using the 24 VDC Power OUT connector of the preceding I/O block, both blocks occupy the same 24 Vdc I/O power segment. However, if you connect an external isolated power supply to the 24 Vdc Power IN connector of a TM7 I/O block, you establish a new 24 Vdc I/O power segment beginning with that I/O block.

I/O block wired with one external 24 Vdc power supply:

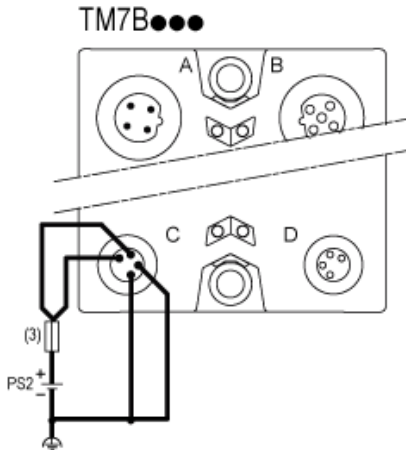

(3) External fuse, Type T slow-blow, 8 A max., 250 V

PS2 External isolated I/O power supply, 24 Vdc