



Glavno

Range of product	Modicon M241
Product or component type	Logic controller
[Us] rated supply voltage	100...240 V AC
Discrete input number	14 discrete input including 8 fast input conforming to IEC 61131-2 Type 1
Discrete output type	Relay Transistor
Discrete output number	6 relay 4 transistor including 4 fast output
Discrete output voltage	24 V DCfor transistor output 5...125 V DCfor relay output 5...250 V ACfor relay output
Discrete output current	2 A with Q4...Q9 terminal(s)for relay output 0.1 A with TR0...TR3 terminal(s)for fast output (PTO mode) 0.5 A with TR0...TR3 terminal(s)for transistor output

Komplementarno

Discrete I/O number	24
Number of I/O expansion module	7 (local I/O architecture) 14 (remote I/O architecture)
Supply voltage limits	85...264 V
Network frequency	50/60 Hz
Discrete input logic	Sink or source
Discrete input voltage	24 V
Discrete input voltage type	DC
Voltage state 1 guaranteed	≥ 15 Vfor input
Voltage state 0 guaranteed	≤ 5 Vfor input
Discrete input current	5 mAfor input
Input impedance	4.7 kOhmfor input
Response time	50 μ s turn-on operation with I0...I13 terminal(s)for input
Configurable filtering time	1 μ sfor fast input
Discrete output logic	Positive logic (source)
Output voltage limits	125 V DC relay output 30 V DC transistor output 277 V AC relay output
Output frequency	≤ 1 kHzfor transistor output ≤ 20 kHzfor fast output (PWM mode) ≤ 100 kHzfor fast output (PLS mode)
Accuracy	+/- 0.1 % at 0.02...0.1 kHzfor fast output +/- 1 % at 0.1...1 kHzfor fast output
Protection type	Short-circuit protectionfor transistor output Short-circuit and overload protection with automatic resetfor transistor output Reverse polarity protectionfor transistor output Without protectionfor relay output
Reset time	10 ms automatic reset output 12 s automatic reset fast output
Memory capacity	8 MBfor program 64 MBfor system memory RAM
Data backed up	128 MB built-in flash memoryfor backup of user programs

Informacije dane u ovoj dokumentaciji sadrže opće opise i/ili tehničke karakteristike o performansama ovdje sadržanih proizvoda. Ova dokumentacija nije namijenjena kao zamjena za niti bi se trebala koristiti za određivanje prikladnosti ili pouzdanosti predmetnih proizvoda za konkretne korisničke primjene. Svaki takav korisnik ili integrator dužan je provesti odgovarajuću i potpunu analizu rizika, procjenu i ispitivanje proizvoda u odnosu na odgovarajuću specifičnu primjenu ili uporabu istog. Niti društvo Schneider Electric Industries SAS niti bilo koje od njegovih povezanih podružnica neće preuzeti obvezu ili snositi odgovornost za pogrešnu upotrebu ovdje sadržanih informacija.

Data storage equipment	<= 16 GB SD card optional
Battery type	BR2032 lithium non-rechargeable, battery life: 4 yr
Backup time	2 years at 25 °C
Execution time for 1 KInstruction	0.3 msfor event and periodic task 0.7 msfor other instruction
Application structure	8 event tasks 4 cyclic master tasks 3 cyclic master tasks + 1 freewheeling task 8 external event tasks
Realtime clock	With
Clock drift	<= 60 s/month at 25 °C
Positioning functions	PTO function 4 channel(s) (positioning frequency: 100 kHz)
Counting input number	4 fast input (HSC mode) at 200 kHz 14 standard input at 1 kHz
Control signal type	A/B signal at 100 kHzfor fast input (HSC mode) Pulse/direction signal at 200 kHzfor fast input (HSC mode) Single phase signal at 200 kHzfor fast input (HSC mode)
Integrated connection type	USB port with connector mini B USB 2.0 Ethernet with connector RJ45 Non isolated serial link "serial 1" with connector RJ45 and interface RS232/RS485 Non isolated serial link "serial 2" with connector removable screw terminal block and interface RS485
Supply	Serial link supply "serial 1" at 5 V, <= 200 mA
Transmission rate	1.2...115.2 kbit/s (115.2 kbit/s by default) for bus length of 15 m - communication protocol: RS485 1.2...115.2 kbit/s (115.2 kbit/s by default) for bus length of 3 m - communication protocol: RS232 480 Mbit/s for bus length of 3 m - communication protocol: USB 10/100 Mbit/s - communication protocol: Ethernet
Communication port protocol	Modbus non isolated serial link with master/slave method
Port Ethernet	1 - 10BASE-T/100BASE-TX port with copper cable support
Communication service	FDR Downloading IEC VAR ACCESS Monitoring NGVL Programming Updating firmware SMS notifications DHCP server (via TM4 Ethernet switch network module) DHCP client (embedded Ethernet port) SNMP client/server FTP client/server SQL client Modbus TCP client I/O scanner Ethernet/IP originator I/O scanner (embedded Ethernet port) Ethernet/IP target, Modbus TCP server and Modbus TCP slave Send and receive email from the controller based on TCP/UDP library Web server (WebVisu & XWeb system) OPC UA server DNS client
Local signalling	1 LED red for module error (ERR) 1 LED green for PWR 1 LED green for RUN 1 LED greenfor SD card access (SD) 1 LED redfor BAT 1 LED greenfor SL1 1 LED greenfor SL2 1 LED per channel greenfor I/O state 1 LED redfor I/O error (I/O) 1 LED redfor bus fault on TM4 (TM4) 1 LED greenfor Ethernet port activity
Electrical connection	Removable screw terminal block for inputs and outputs (pitch 5.08 mm) Removable screw terminal block for connecting the 24 V DC power supply (pitch 5.08 mm)
Cable distance between devices	Unshielded cable: <= 50 m for input Shielded cable: <= 10 m for fast input Unshielded cable: <= 50 m for output Shielded cable: <= 3 m for fast output
Insulation	500 V AC between supply and internal logic Non-insulated between supply and ground

Marking	CE
Sensor power supply	24 V DC at 400 mA supplied by the controller
Surge withstand	2 kVfor power lines (AC) in common mode conforming to EN/IEC 61000-4-5 2 kVfor relay output in common mode conforming to EN/IEC 61000-4-5 1 kVfor shielded cable in common mode conforming to EN/IEC 61000-4-5 1 kVfor power lines (AC) in differential mode conforming to EN/IEC 61000-4-5 1 kVfor relay output in differential mode conforming to EN/IEC 61000-4-5 1 kVfor input in common mode conforming to EN/IEC 61000-4-5 1 kVfor transistor output in common mode conforming to EN/IEC 61000-4-5
Web services	Web server
Maximum number of connections	8 connection(s) for Modbus server 8 connection(s) for SoMachine protocol 10 connection(s) for web server 4 connection(s) for FTP server 16 connection(s) for Ethernet/IP target 8 connection(s) for Modbus client
Number of slave	16 Ethernet/IP 64 Modbus TCP
Cycle time	10 ms 16 Ethernet/IP 64 ms 64 Modbus TCP
Mounting support	Top hat type TH35-15 rail conforming to IEC 60715 Top hat type TH35-7.5 rail conforming to IEC 60715 Plate or panel with fixing kit
Height	90 mm
Depth	95 mm
Width	150 mm
Product weight	0.53 kg

Okolina

standards	UL 508 CSA C22.2 No 142 ANSI/ISA 12-12-01 UL 1604 CSA C22.2 No 213 EN/IEC 61131-2: 2007 Marine specification (LR, ABS, DNV, GL)
product certifications	CSA CULus IACS E10 RCM
resistance to electrostatic discharge	4 kV on contact conforming to EN/IEC 61000-4-2 8 kV in air conforming to EN/IEC 61000-4-2
resistance to electromagnetic fields	10 V/m (80 MHz...1 GHz) conforming to EN/IEC 61000-4-3 3 V/m (1.4 GHz...2 GHz) conforming to EN/IEC 61000-4-3 1 V/m (2 GHz...3 GHz) conforming to EN/IEC 61000-4-3
resistance to fast transients	2 kVfor power lines conforming to EN/IEC 61000-4-4 2 kVfor relay output conforming to EN/IEC 61000-4-4 1 kVfor Ethernet line conforming to EN/IEC 61000-4-4 1 kVfor serial link conforming to EN/IEC 61000-4-4 1 kVfor input conforming to EN/IEC 61000-4-4 1 kVfor transistor output conforming to EN/IEC 61000-4-4
resistance to conducted disturbances	10 V (0.15...80 MHz) conforming to EN/IEC 61000-4-6 3 V (0.1...80 MHz) conforming to Marine specification (LR, ABS, DNV, GL) 10 V (spot frequency (2, 3, 4, 6.2, 8.2, 12.6, 16.5, 18.8, 22, 25 MHz)) conforming to Marine specification (LR, ABS, DNV, GL)
electromagnetic emission	Conducted emissions, test level: 120...69 dB μ V/m QP, condition of test: power lines (radio frequency: 10...150 kHz) conforming to EN/IEC 55011 Conducted emissions, test level: 63 dB μ V/m QP, condition of test: power lines (radio frequency: 1.5...30 MHz) conforming to EN/IEC 55011 Conducted emissions, test level: 79 dB μ V/m QP/66 dB μ V/m AV, condition of test: power lines (radio frequency: 0.15...0.5 MHz) conforming to EN/IEC 55011 Conducted emissions, test level: 73 dB μ V/m QP/60 dB μ V/m AV, condition of test: power lines (radio frequency: 0.5...300 MHz) conforming to EN/IEC 55011 Radiated emissions, test level: 40 dB μ V/m QP with class A, condition of test: 10 m (radio frequency: 30...230 MHz) conforming to EN/IEC 55011 Conducted emissions, test level: 79...63 dB μ V/m QP, condition of test: power lines (radio frequency: 150...1500 kHz) conforming to EN/IEC 55011 Radiated emissions, test level: 47 dB μ V/m QP with class A, condition of test: 10 m (radio frequency: 230...1000 MHz) conforming to EN/IEC 55011
immunity to microbreaks	10 ms

ambient air temperature for operation	-10...55 °C for horizontal installation -10...50 °C for vertical installation
ambient air temperature for storage	-25...70 °C
relative humidity	10...95 % without condensation in operation 10...95 % without condensation in storage
IP degree of protection	IP20 with protective cover in place
pollution degree	2
operating altitude	0...2000 m
storage altitude	0...3000 m
vibration resistance	3.5 mm (vibration frequency: 5...8.4 Hz) on symmetrical rail 3 gn (vibration frequency: 8.4...150 Hz) on symmetrical rail 3.5 mm (vibration frequency: 5...8.4 Hz) on panel mounting 3 gn (vibration frequency: 8.4...150 Hz) on panel mounting
shock resistance	15 gn for 11 ms

Offer Sustainability

Green Premium product	Green Premium product
Compliant - since 1350 - Schneider Electric declaration of conformity	Compliant - since 1350 - Schneider Electric declaration of conformity
Reference contains SVHC above the threshold - go to CaP for more details	Reference contains SVHC above the threshold
Available	Available
Available	Available

Dimensions

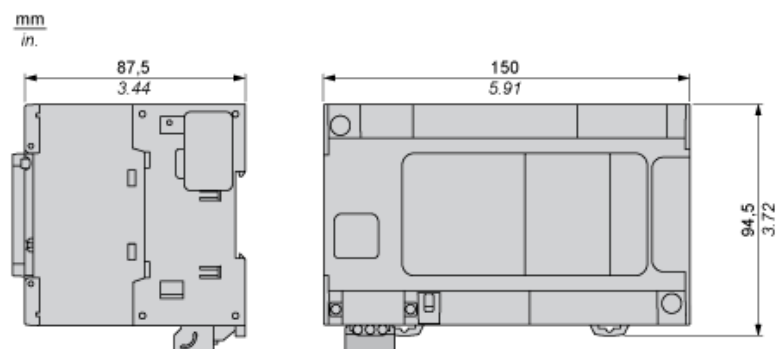

Clearance

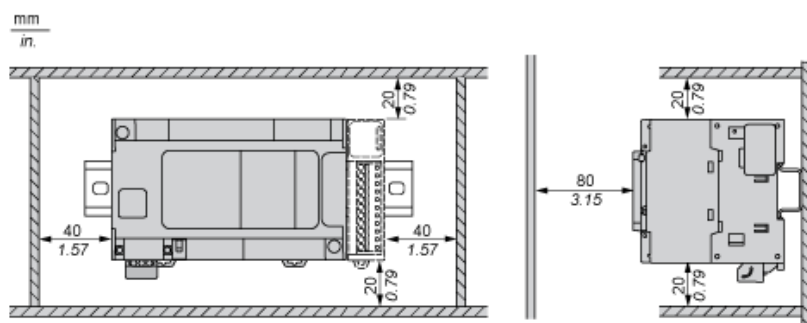

Mounting Position

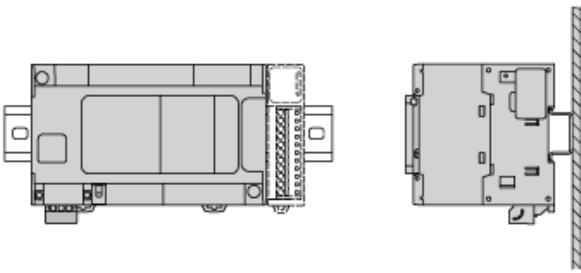

Acceptable Mounting

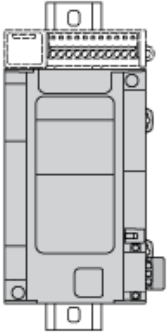

NOTE: Expansion modules must be mounted above the logic controller.

Incorrect Mounting

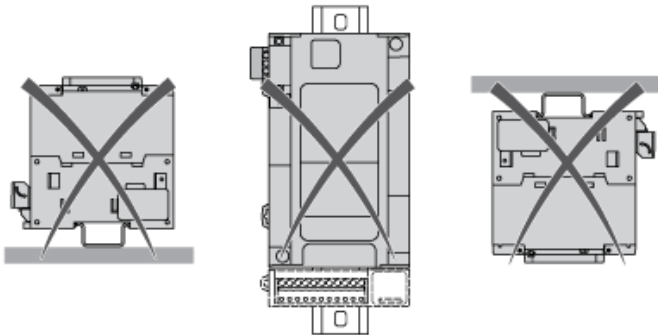

Direct Mounting On a Panel Surface

Mounting Hole Layout

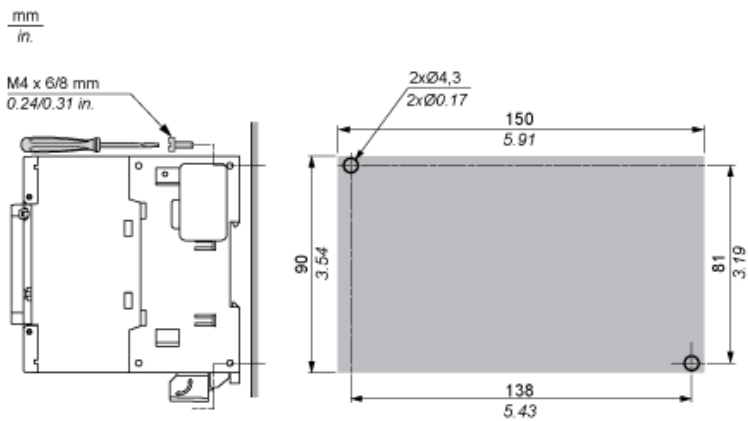

Digital Inputs

Wiring Diagram (Positive Logic)

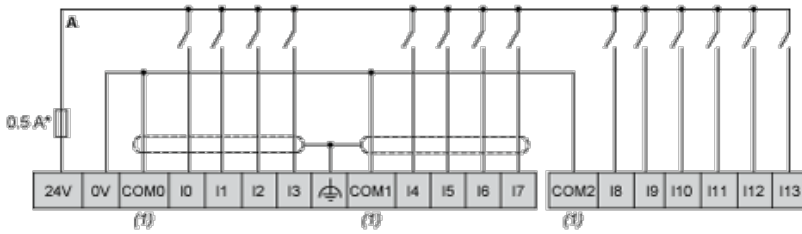

(*) : Type T fuse

(1) : The COM0, COM1 and COM2 terminals are not connected internally.

Wiring Diagram (Negative Logic)

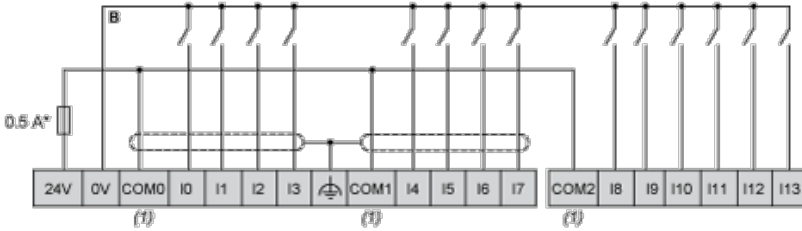

(*) : Type T fuse

(1) : The COM0, COM1 and COM2 terminals are not connected internally.

Fast Transistor Outputs

Wiring Diagram

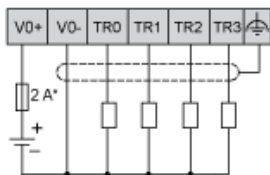

(*) : 2 A fast-blow fuse

Relay Outputs

Wiring Diagram

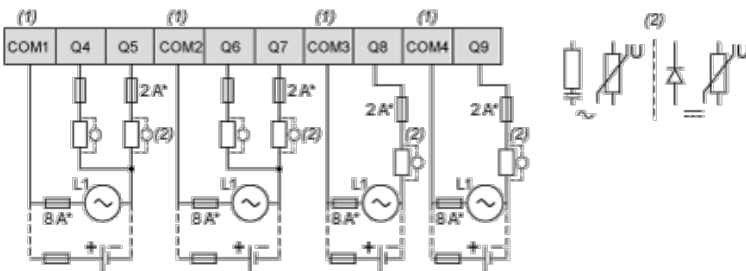

(*) : Type T fuse

(1) : The terminals COM1 to COM4 are not connected internally.

(2) : To improve the life time of the contacts, and to protect from potential inductive load damage, you must connect a free wheeling diode in parallel to each inductive DC load or an RC snubber in parallel of each inductive AC load

USB Mini-B Connection

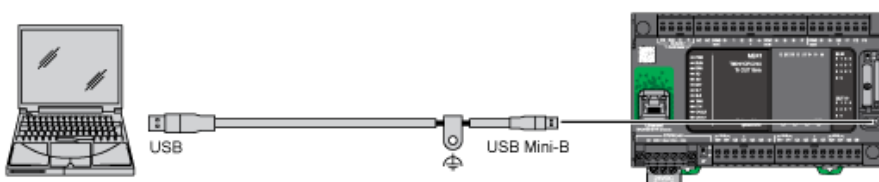

Ethernet Connection to a PC

