

XVUZ01

jedinica za pričvršćivanje - 3 vijka - za izravno
montiranje - crna



Glavno

Range of product	Harmony XVU
Product or component type	Modular tower light
Accessory / separate part type	Mounting plate
Accessory / separate part category	Mounting and fixing accessory
Component name	XVU
Mounting diameter	60 mm

Komplementarno

Pin number	3
Mounting support	Direct mounting
Product compatibility	Top: AC body Top: DC body Top: swivel mounting support
Material	ABS (acrylonitrile butadiene-styrene) PC (polycarbonate) PBT (polybutylene terephthalate) V-0 flame retardant conforming to UL 94
Housing colour	Black
Connections - terminals	Push-in
[Us] rated supply voltage	110...240 V AC 24 V AC/DC
Length	17 mm
Product weight	0.063 kg

Okolina

ambient air temperature for storage	-40...70 °C
ambient air temperature for operation	-25...50 °C
IP degree of protection	IP65
product certifications	CE CSA UL

Offer Sustainability

Green Premium product	Green Premium product
Compliant - since 1529 - Schneider Electric declaration of conformity	Compliant - since 1529 - Schneider Electric declaration of conformity
Reference not containing SVHC above the threshold	Reference not containing SVHC above the threshold
Available	Available
Available	Available

Fixing Unit

Dimensions

Informacije dane u ovoj dokumentaciji sadrže opće opise i/ili tehničke karakteristike o performansama ovdje sadržanih proizvoda. Ova dokumentacija nije namijenjena kao zamjena za niti bi se trebala koristiti za određivanje prikladnosti ili pouzdanosti predmetnih proizvoda za konkretne korisničke primjene. Svaki takav korisnik ili integrator dužan je provesti odgovarajuću i potpunu analizu rizika, procjenu i ispitivanje specifičnu primjenu ili uporabu istog. Niti društvo Schneider Electric Industries SAS niti bilo koje od njegovih povezanih poduzeća ili podružnica neće preuzeti obvezu ili snositi odgovornost za pogrešnu upotrebu ovdje sadržanih informacija.

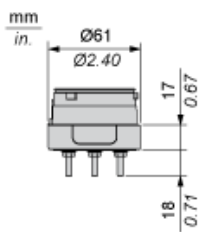

Modular Tower Lights Mounting

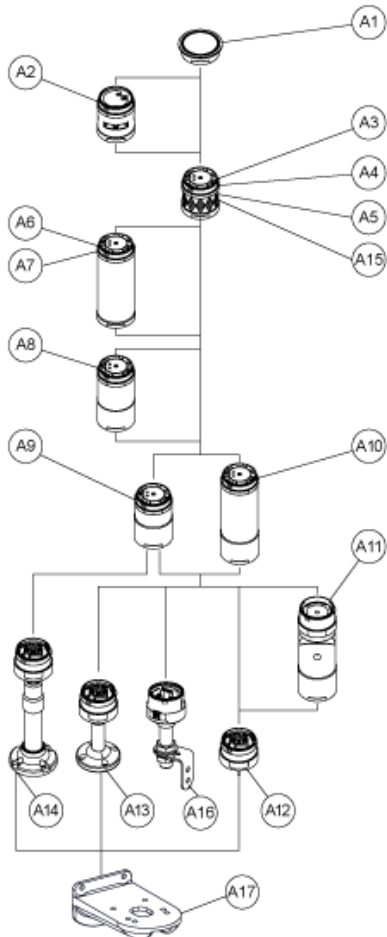

Drawing	Part number	Part name
A1	-	Top cover
	-	Top cover (Silver)
A2	XVUC9S	Buzzer unit
	XVUC9SQ	Buzzer unit (Silver)
A3	XVUC23	Green LED unit
	XVUC24	Red LED unit
	XVUC25	Orange LED unit
	XVUC26	Blue LED unit
	XVUC27	White LED unit
	XVUC28	Yellow LED unit
A4	XVUC29	Multi-LED unit
A5	XVUC29P	Multi-LED unit, Pulse signal
A6	XVUC9V	Sound unit

A7	XVUC9VP	Sound unit, Pulse signal
A8	XVUC020	Extender
	XVUC020Q	Extender (Silver)
A9	XVUC21B	DC body
	XVUC21BQ	DC body (Silver)
A10	XVUC21M	AC body NPN
	XVUC21MP	AC body PNP
	XVUC21MQP	AC body PNP (Silver)
A11	XVUZ06	Flexible option
A12	XVUZ01	Fixing Unit - Direct mounting (3 pins)
	XVUZ01Q	Fixing Unit - Direct mounting (Silver,3 pins)
	XVUZ03	Fixing Unit - Direct mounting (2 pins)
	XVUZ04	Fixing Unit - Direct mounting (4 pins)
A13	XVUZ02	Fixing Unit - Plate with Pole (100 mm)
	XVUZ02Q	Fixing Unit - Plate with Pole (100 mm, Silver)
	XVUZ400	Fixing Unit - Plate with Pole (400 mm)
	XVUZ800	Fixing Unit - Plate with Pole (800 mm)
A14	XVUZ05	Fixing Unit - Plate with adjustment pole (100-385 mm)
A15	XVUC43	Green LED unit, Flash
	XVUC44	Red LED unit, Flash
	XVUC45	Orange LED unit, Flash
	XVUC46	Blue LED unit, Flash
	XVUC47	White LED unit, Flash
	XVUC48	Yellow LED unit, Flash
A16	XVUZ100T	Fixing Unit - Metal bracket with pole (100 mm)
	XVUZ250T	Fixing Unit - Metal bracket with pole(250 mm)
	XVUZ400T	Fixing Unit - Metal bracket with pole (400 mm)
A17	XVUZ12	Fixing plate for use on vertical support - black

Modular Tower Lights Mounting

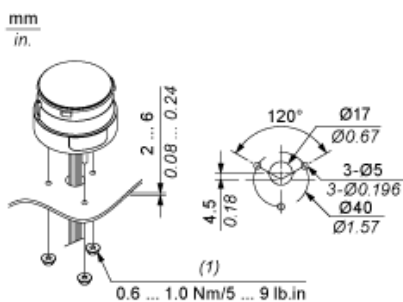

(1) M4 Nut x 3 (attached)

Flexible Option Mounting

Recommended Mounting

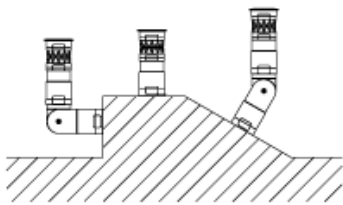

No Recommended Mounting

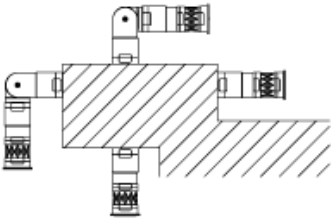

Illuminated Units, Multi-LED and Audible Units Wiring

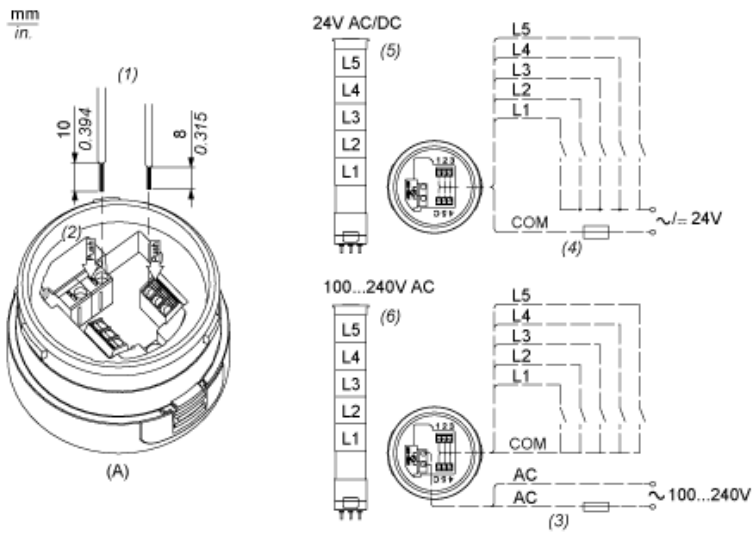

- (A) Fixing Unit
- (1) Dimensions of Wiring size
- (2) Push-in Wire Connectors
- (3) Fuse : 2A ,250V
- (4) Fuse : 0.5A ,125V
- (5) Modular Tower Lights 24V AC/DC
- (6) Modular Tower Lights 100...240V AC
- L1 Illuminated LED Units
- to
- L5 :