

XU2N18PP341

fotoelektrični senzor–XU2–prolazna zraka–Sn 15 m–
12..24 V DC–kabel od 2 m



Glavno

Range of product	OsiSense XU
Series name	Application food and beverage
Electronic sensor type	Photo-electric sensor
Sensor name	XU2
Sensor design	Cylindrical M18
Detection system	Thru beam
Material	Stainless steel
Line of sight type	Axial
Type of output signal	Discrete
Supply circuit type	DC
Wiring technique	3-wire
Discrete output type	PNP
Discrete output function	1 NO or 1 NC programmable
Electrical connection	Cable
Cable length	2 m
Product specific application	-
Emission	Infrared thru beam
[Sn] nominal sensing distance	15 m thru beam

Komplementarno

Enclosure material	Stainless steel : 304 CU
Lens material	PMMA
Maximum sensing distance	20 m
Output type	Solid state
Add on output	Without
Add on input	Breaking test + programming
Cable composition	4 x 0.34 mm ²
Wire insulation material	PvR
Cable outer diameter	4.2 mm
Status LED	1 LED (green) for supply on 1 LED (yellow) for output state
[Us] rated supply voltage	12...24 V DC with reverse polarity protection
Supply voltage limits	10...30 V DC
Switching capacity in mA	<= 100 mA (overload and short-circuit protection)
Switching frequency	<= 500 Hz
Voltage drop	<= 1.5 V (closed state)
Current consumption	<= 50 mA (no-load)
Delay first up	<= 15 ms
Delay response	<= 1 ms
Delay recovery	<= 1 ms
Setting-up	Without sensitivity adjustment
Diameter	18 mm
Length	62 mm
Product weight	0.27 kg
Kit composition	Transmitter + receiver

Informacije dane u ovoj dokumentaciji sadrže opće opise i/ili tehničke karakteristike o performansama ovdje sadržanih proizvoda.
Ova dokumentacija nije namijenjena kao zamjena za niti bi se trebala koristiti za određivanje prikladnosti ili pouzdanosti predmetnih proizvoda za konkretne korisničke primjene.
Svaki takav korisnik ili integrator dužan je provesti odgovarajuću i potpunu analizu rizika, procjenu i ispitivanje proizvoda u odnosu na odgovarajuću specifičnu primjenu ili uporabu istog.
Niti društvo Schneider Electric, Industries SAS niti bilo koje od njegovih povezanih poduzeća ili podružnica neće preuzeti obvezu ili snositi odgovornost za pogrešnu upotrebu ovdje sadržanih informacija.

Okolina

product certifications	CE CSA UL
ambient air temperature for operation	-25...55 °C
ambient air temperature for storage	-40...70 °C
vibration resistance	25 gn, amplitude = +/- 1.5 mm (f = 10...55 Hz) conforming to IEC 60068-2-6
shock resistance	30 gn (duration = 11 ms) conforming to IEC 60068-2-27
IP degree of protection	IP67 conforming to IEC 60529

Offer Sustainability

Not Green Premium product	Not Green Premium product
Will be Compliant on 3Q2013	Will be Compliant on 3Q2013 Will be Compliant on 3Q2013
Available	Available
Available	Available

Contractual warranty

Warranty period	18 months
-----------------	-----------

Dimensions

Transmitter's Dimensions

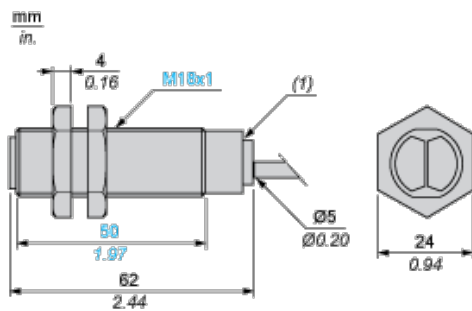

(1) LED

Receiver's Dimensions

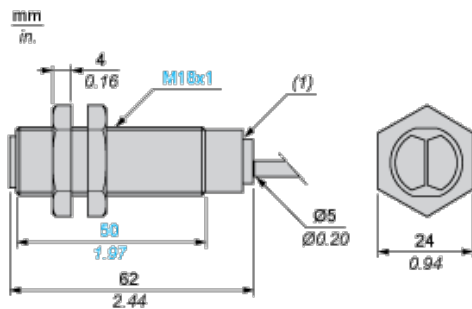

(1) LED

Mounting and Clearance

Fixing nut tightening torque: < 15 N.m

Connector tightening torque: 2 N.m

Wiring Schemes

Transmitter

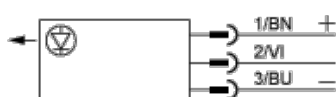

BN : Brown

VI : Violet (beam break input)

BU : Blue

3-wire, PNP NO or NC Programmable Function

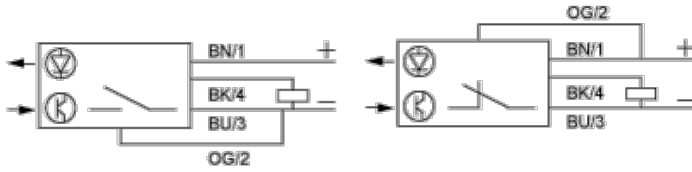

BN : Brown

BK : Black (out / output)

BU : Blue

OG : Orange (program)

Wiring Schemes

Beam Break Input on Thru-beam Transmitter

Beam made

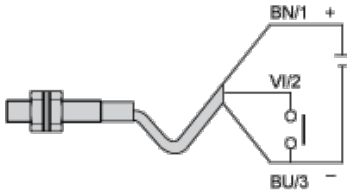

BN : Brown

VI : Violet (beam break input)

BU : Blue

Beam broken

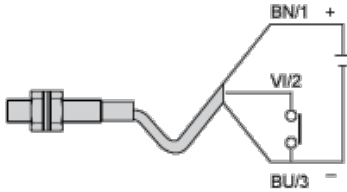

BN : Brown

VI : Violet (beam break input)

BU : Blue

Detection Curves

Thru-beam System

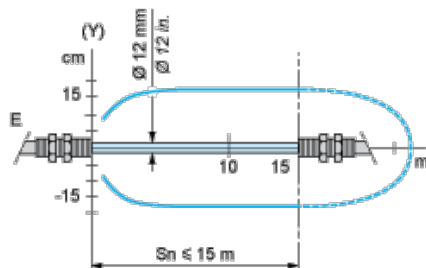

(y) Ø of beam

Excess Gain Curves (Ambient Temperature: + 25° C)

Thru-beam System

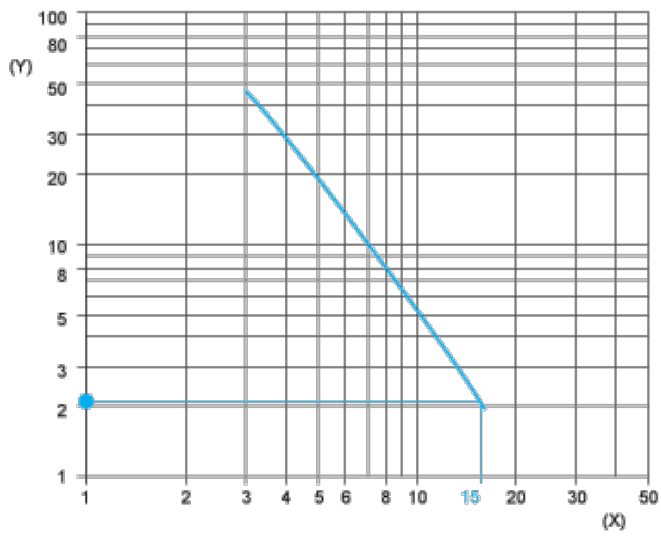

(y) Gain

(x) Distance (m)