

## XMLBL05R2S12

vlačna sklopka XMLB 50 mbar – 2 podesiva praga –  
1 C/O

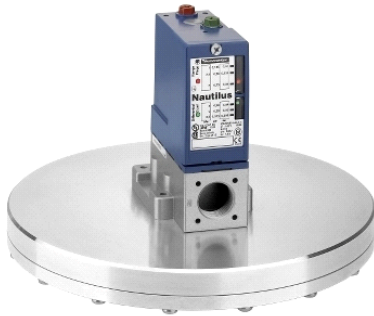

### Glavno

Range of product	OsiSense XM
Product or component type	Electromechanical pressure sensor
Pressure sensor type	Electromechanical pressure sensor
Device short name	XMLB
Pressure sensor size	0.05 bar
Controlled fluid	Air (0...160 °C) Hydraulic oil (0...160 °C)
Fluid connection type	G 1/4 (female) conforming to ISO 228
Electrical connection	Screw-clamps terminals 1 x 0.5...2 x 2.5 mm <sup>2</sup>
AWG gauge	AWG 20...AWG 14
Cable entry	Cable gland 7...13 mm
Contacts type and composition	1 C/O
Product specific application	-
Pressure switch type of operation	Regulation between 2 thresholds
Electrical circuit type	Control circuit
Scale type	Adjustable differential
Local display	With
Adjustable range of switching point on rising pressure	0.0026...0.05 bar
Adjustable range of switching point on falling pressure	0.0012...0.046 bar
Possible differential maximum at 0.04 bar high setting	
Maximum permissible accidental pressure	0.1125 bar
Destruction pressure	0.225 bar
Pressure actuator	Diaphragm
Materials in contact with fluid	Aluminium FPM, FKM
Enclosure material	Zinc alloy
[In] rated current	3 A, B300, AC-15 (Ue = 120 V) conforming to EN/IEC 60947-5-1 1.5 A, B300, AC-15 (Ue = 240 V) conforming to EN/IEC 60947-5-1 0.1 A, R300, DC-13 (Ue = 250 V) conforming to EN/IEC 60947-5-1

### Komplementarno

Possible differential minimum at low setting	0.0014 bar (- 0.8 mbar, + 1.1 mbar)
Possible differential minimum at high setting	0.004 bar (+/- 1.4 mbar)
Maximum permissible pressure - per cycle	0.625 bar
Terminal block type	4 terminals
Operating rate	120 cyc/mn
Repeat accuracy	< 2 %
[Uj] rated insulation voltage	500 V conforming to EN/IEC 60947-1 300 V conforming to UL 508 300 V conforming to CSA C22.2 No 14
[Uimp] rated impulse withstand voltage	6 kV conforming to EN/IEC 60947-1
Auxiliary contacts operation	Snap action
Contacts material	Silver contacts

Informacije dane u ovoj dokumentaciji sadrže opće i/ili tehničke karakteristike o performansama ovdje sadržanih proizvoda. Ova dokumentacija nije namijenjena kao zamjena za niti bi se trebala koristiti za određivanje prikladnosti ili pouzdanosti predmetnih proizvoda za konkretne korisničke primjene. Svaki takav korisnik ili integrator dužan je provesti odgovarajuću i potpunu analizu rizika, procjenu i ispitivanje proizvoda u odnosu na odgovarajuću specifičnu primjenu ili uporabu istog. Niti društvo Schneider Electric Industries SAS niti bilo koje od njegovih povezanih poduzeća ili podružnica neće preuzeti obvezu ili snositi odgovornost za pogrešnu upotrebu ovdje sadržanih informacija.

Resistance across terminals	< 25 mOhm conforming to IEC 255-7 category 3 < 25 mOhm conforming to NF C 93-050 method A
Short-circuit protection	10 A cartridge fuse type gG (gl)
Mechanical durability	6000000 cycles
Setting	External
Height	145 mm
Depth	204 mm
Width	200 mm
Product weight	2.42 kg

## Okolina

standards	CE EN/IEC 60947-5-1 UL 508 CSA C22.2 No 14
product certifications	BV CCC CSA LROS (Lloyds register of shipping) UL EAC
protective treatment	TC (standard version)
ambient air temperature for operation	-25...70 °C
ambient air temperature for storage	-40...70 °C
operating position	Any position
vibration resistance	4 gn (f = 30...500 Hz) conforming to IEC 60068-2-6
shock resistance	50 gn conforming to IEC 60068-2-27
electrical shock protection class	Class I conforming to IEC 1140 Class I conforming to IEC 536 Class I conforming to NF C 20-030
IP degree of protection	IP66 conforming to EN/IEC 60529

## Offer Sustainability

Not Green Premium product	Not Green Premium product
Compliant - since 0928 - Schneider Electric declaration of conformity	Compliant - since 0928 - Schneider Electric declaration of conformity
Reference not containing SVHC above the threshold	Reference not containing SVHC above the threshold
Need no specific recycling operations	Need no specific recycling operations

## Contractual warranty

Warranty period	18 months
-----------------	-----------

## Dimensions

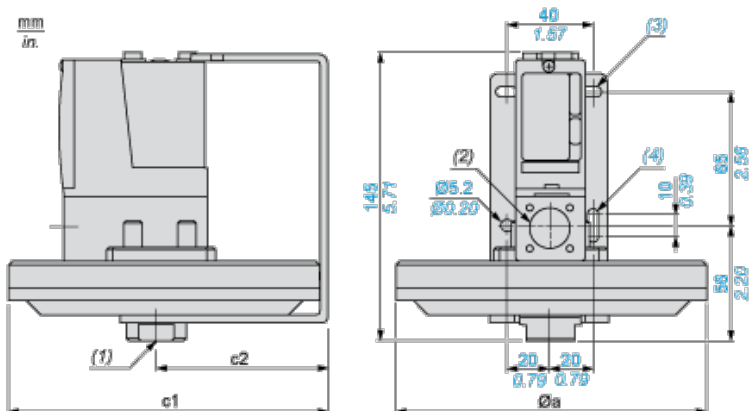

$\varnothing a$  200

=

c1 = 204

c2 = 104

- (1) 1 fluid entry, tapped G1/4 (BSP female)
- (2) 1 electrical connections entry, tapped M20 x 1.5
- (3) 2 elongated holes  $\varnothing$  10.2 x 5.2
- (4) 1 elongated hole  $\varnothing$  15.2 x 5.2

## Wiring Diagram

### Terminal Model

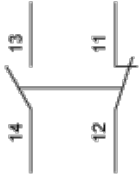

## Operating Curves

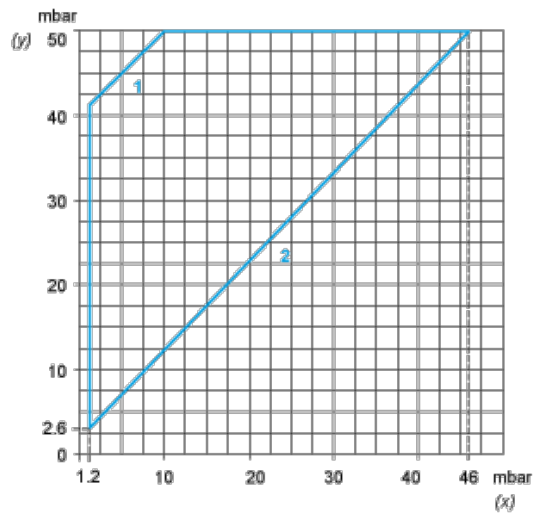

- (y) Rising pressure
- (x) Falling pressure
- 1 : Maximum differential
- 2 : Minimum differential

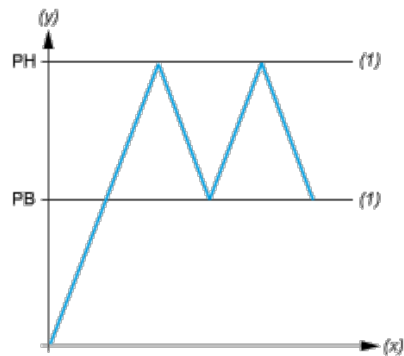

- (y) Pressure
- (x) Time
- (1) Adjustable value
- PH : High point
- PB : Below point