

XBKP50100U20M

brojač unaprijed određenog zbrajanja – mehanički
zaslon s 5 znamenki – 24 V DC



Glavno

Range of product	Zelio Count
Product or component type	Preselection counter
Display type	Mechanical
Size	75 x 60 mm
Display digits	5 digit(s)
Counting frequency	25 Hz
Reset	Manual or electrical reset
Counting capacity	0...99999
Technology type	Electromechanical

Komplementarno

[Us] rated supply voltage	24 V DC (Us +/- 10 %)
Power consumption in W	2.5 W
Output type	Contact (volt-free)
Preset number	1
Counting mode	Adding Substracting
Input type	Contact (20 VA/220 V/1 A maximum)
Mounting mode	Flush-mounted Removable
Mounting support	Panel mounting
Fixing mode	By screws
Connections - terminals	AMP lugs on connection box
Height	75 mm
Number of outputs	1
Product weight	0.24 kg
Width	60 mm
Product destination	Cable
CAD overall width	60 mm
CAD overall height	75 mm
CAD overall depth	102 mm
Contacts usage	Volt-free contacts
Input current	0...1 A
Rotary handle fixing	Screws

Okolina

standards	EN 50081-2 EN 50082-2 EN 61010
product certifications	CE
IP degree of protection	IP40 conforming to IEC 60529
ambient air temperature for operation	-10...50 °C
ambient air temperature for storage	-40...85 °C
vibration resistance	5 gn (f = 10...150 Hz) conforming to IEC 60068-2-6
shock resistance	30 gn for 6 ms conforming to IEC 60068-2-27
electrical shock protection class	Class II conforming to IEC 60536

Informacije dane u ovoj dokumentaciji sadrže opće opise i/ili tehničke karakteristike o performansama ovdje sadržanih proizvoda.
Ova dokumentacija nije namijenjena kao zamjena za niti bi se trebala koristiti za određivanje prikladnosti ili pouzdanosti predmetnih proizvoda za konkretne korisničke primjene.
Svaki takav korisnik ili integrator dužan je provesti odgovarajuću i potpunu analizu rizika, procjenu i ispitivanje proizvoda u odnosu na odgovarajuću specifičnu primjenu ili uporabu istog.
Niti društvo Schneider Electric Industries SAS niti bilo koje od njegovih povezanih poduzeća ili podružnica neće preuzeti obvezu ili snositi odgovornost za pogrešnu upotrebu ovdje sadržanih informacija.

Contractual warranty

Warranty period

18 months

Electromechanical Preset Counters

Subtracting Preset Counters with Mechanical Display

XBKP50100D•0M

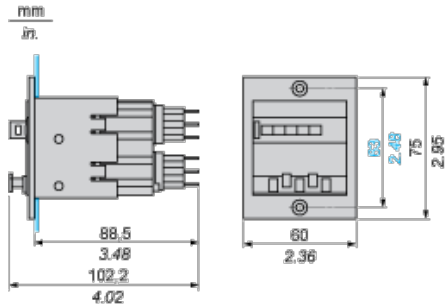

Flush-Mounting

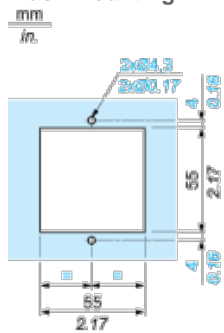

Adding Preset Counters with Mechanical Display

XBKP50100D•0M

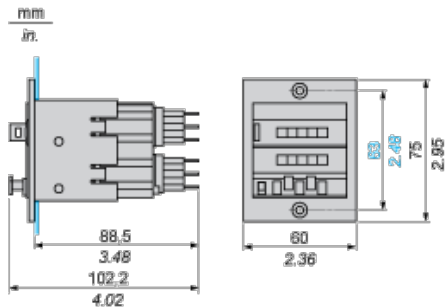

Flush-Mounting

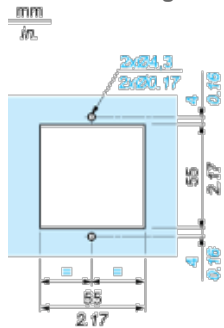

Wiring Diagram of Electromechanical Preset Counters

24 Vdc Supply Voltage

XBKP50100D•0M, XBKP50100U•0M

