



Glavno

Range of product	Modicon TM7
Product or component type	CANopen interface I/O block
Range compatibility	Modicon LMC058 Modicon M258
Enclosure material	Plastic
Bus type	CANopen
[Ue] rated operational voltage	24 V DC
Input/output number	16
Input/output number of splitter box	16 I/O

Komplementarno

Discrete input number	0...16 input(s) configurable by software
Discrete input voltage	24 V
Discrete input voltage type	DC
Discrete input current	4.4 mA
Discrete input logic	Positive
Discrete output number	0...16 output(s) configurable by software
Discrete output voltage	24 V
Discrete output voltage type	DC
Discrete output current	<= 0.5 A
Discrete output type	Transistor
Sensor power supply	24 V, 500 mA for all channels with overload, short-circuit and reverse polarity protection
Electrical connection	1 male connector M12 - A coding - 5 ways for CANopen bus IN 1 female connector M12 - B coding - 4 ways for TM7 bus OUT 1 male connector M8 - 4 ways for power IN 1 female connector M8 - 4 ways for power OUT 1 female connector M12 - A coding - 5 ways for CANopen bus OUT 8 female connectors M12 - A coding - 5 ways for sensor or actuator
Local signalling	2 LEDs for bus diagnostic 1 LED for actuator power supply diagnostics 1 LED for sensor power supply diagnostics
Operating position	Any position
Fixing mode	By 2 screws
Product weight	0.32 kg

Okolina

standards	IEC 61131-2
product certifications	C-Tick CURus GOST-R ATEX II 3g EEx nA II T5
marking	CE
ambient air temperature for operation	-10...60 °C
ambient air temperature for storage	-25...85 °C
relative humidity	5...95 % without condensation or dripping water
pollution degree	2 conforming to IEC 60664
IP degree of protection	IP67 conforming to IEC 61131-2

Informacije dane u ovoj dokumentaciji sadrže opće opise i/ili tehničke karakteristike o performansama ovdje sadržanih proizvoda. Ova dokumentacija nije namijenjena kao zamjena za niti bi se trebala koristiti za određivanje prikladnosti ili pouzdanosti predmetnih proizvoda za konkretne korisničke primjene. Svaki takav korisnik ili integrator dužan je provesti odgovarajuću i potpunu analizu rizika, procjenu i ispitivanje proizvoda u odnosu na odgovarajuću specifičnu primjenu ili uporabu istog. Niti društvo Schneider Electric, Industries SAS niti bilo koje od njegovih povezanih poduzeća ili podružnica neće preuzeti obvezu ili snositi odgovornost za pogrešnu upotrebu ovdje sadržanih informacija.

operating altitude	0...2000 m
storage altitude	0...3000 m
vibration resistance	7.5 mm constant amplitude (f = 2...8 Hz) conforming to IEC 60721-3-5 Class 5M3 2 gn constant acceleration (f = 8...200 Hz) conforming to IEC 60721-3-5 Class 5M3 4 gn constant acceleration (f = 200...500 Hz) conforming to IEC 60721-3-5 Class 5M3
shock resistance	30 gn for 11 ms conforming to IEC 60721-3-5 Class 5M3
resistance to electrostatic discharge	8 kV in air conforming to EN/IEC 61000-4-2 6 kV in contact conforming to EN/IEC 61000-4-2
resistance to electromagnetic fields	10 V/m (f = 0.08...2 Hz conforming to EN/IEC 61000-4-3 1 V/m (f = 2...2.7 Hz conforming to EN/IEC 61000-4-3
resistance to fast transients	1 kV shielded cable conforming to EN/IEC 61000-4-4 2 kV power supply conforming to EN/IEC 61000-4-4 1 kV input/output conforming to EN/IEC 61000-4-4
surge withstand	1 kV power supply (common mode) conforming to EN/IEC 61000-4-5 0.5 kV power supply (differential mode) conforming to EN/IEC 61000-4-5 1 kV unshielded links (common mode) conforming to EN/IEC 61000-4-5 0.5 kV unshielded links (differential mode) conforming to EN/IEC 61000-4-5 1 kV shielded links (common mode) conforming to EN/IEC 61000-4-5 0.5 kV shielded links (differential mode) conforming to EN/IEC 61000-4-5
electromagnetic compatibility	EN/IEC 61000-4-6
disturbance radiated/conducted	CISPR 11

Offer Sustainability

Green Premium product	Green Premium product
Compliant - since 1039 - Schneider Electric declaration of conformity	Compliant - since 1039 - Schneider Electric declaration of conformity
Reference not containing SVHC above the threshold	Reference not containing SVHC above the threshold
Available	Available
Available	Available

Contractual warranty

Warranty period	18 months
-----------------	-----------

TM7 CANopen Interface I/O Block

Description

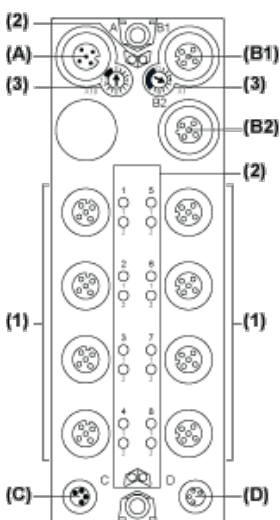

- (A) CANopen bus IN connector
- (B1) CANopen bus OUT connector
- (B2) TM7 bus OUT connector
- (C) 24 Vdc power IN connector
- (D) 24 Vdc power OUT connector
- (1) Input / Output connectors
- (2) Status and channel LEDs
- (3) CANopen Address settings rotary switches

Connector and Channel Assignments

I/O connectors	Channel types	Channels
1	Input/Output	I0/Q0
2	Input/Output	I1/Q1
3	Input/Output	I2/Q2
4	Input/Output	I3/Q3
5	Input/Output	I4/Q4
6	Input/Output	I5/Q5
7	Input/Output	I6/Q6
8	Input/Output	I7/Q7
9	Input/Output	I8/Q8
10	Input/Output	I9/Q9
11	Input/Output	I10/Q10
12	Input/Output	I11/Q11
13	Input/Output	I12/Q12
14	Input/Output	I13/Q13
15	Input/Output	I14/Q14
16	Input/Output	I15/Q15

TM7 Block, Size 2

Dimensions

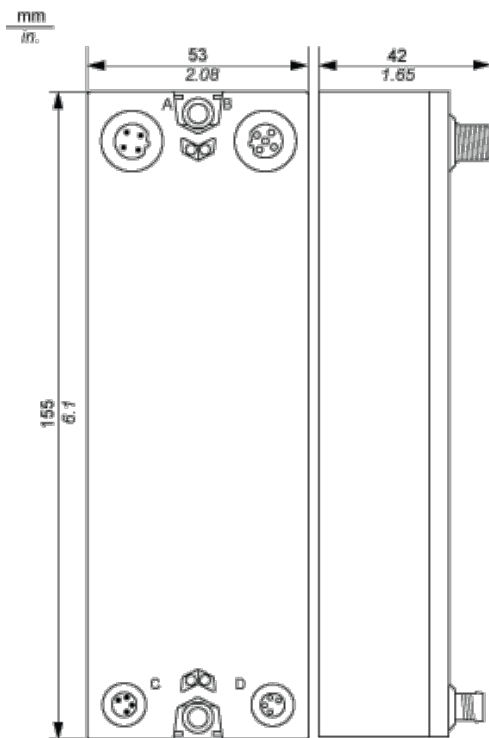

Spacing Requirements

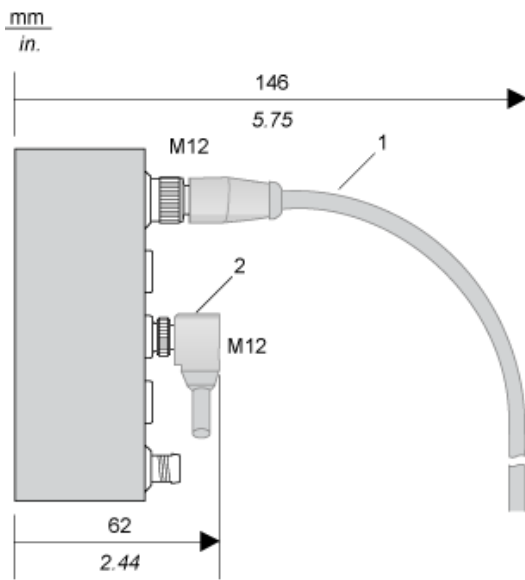

- 1 Straight cable
- 2 Elbowed cable

Installation Guidelines

TM7 Block on an Aluminium Frame

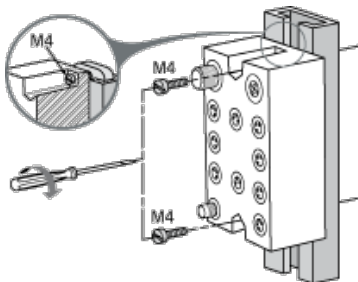

NOTE: Maximum torque to fasten the required M4 screws is 0.6 N.m (5.3 lbf-in).

TM7 Block on a DIN Rail

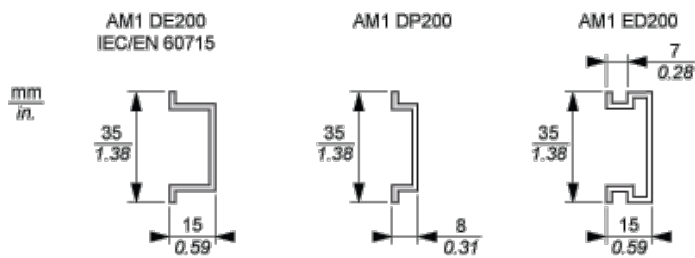

NOTE: Only size 1 (smallest) blocks can be installed on DIN rail with the TM7ACMP mounting plate.

TM7 Block Directly on the Machine

Drilling template of the block:

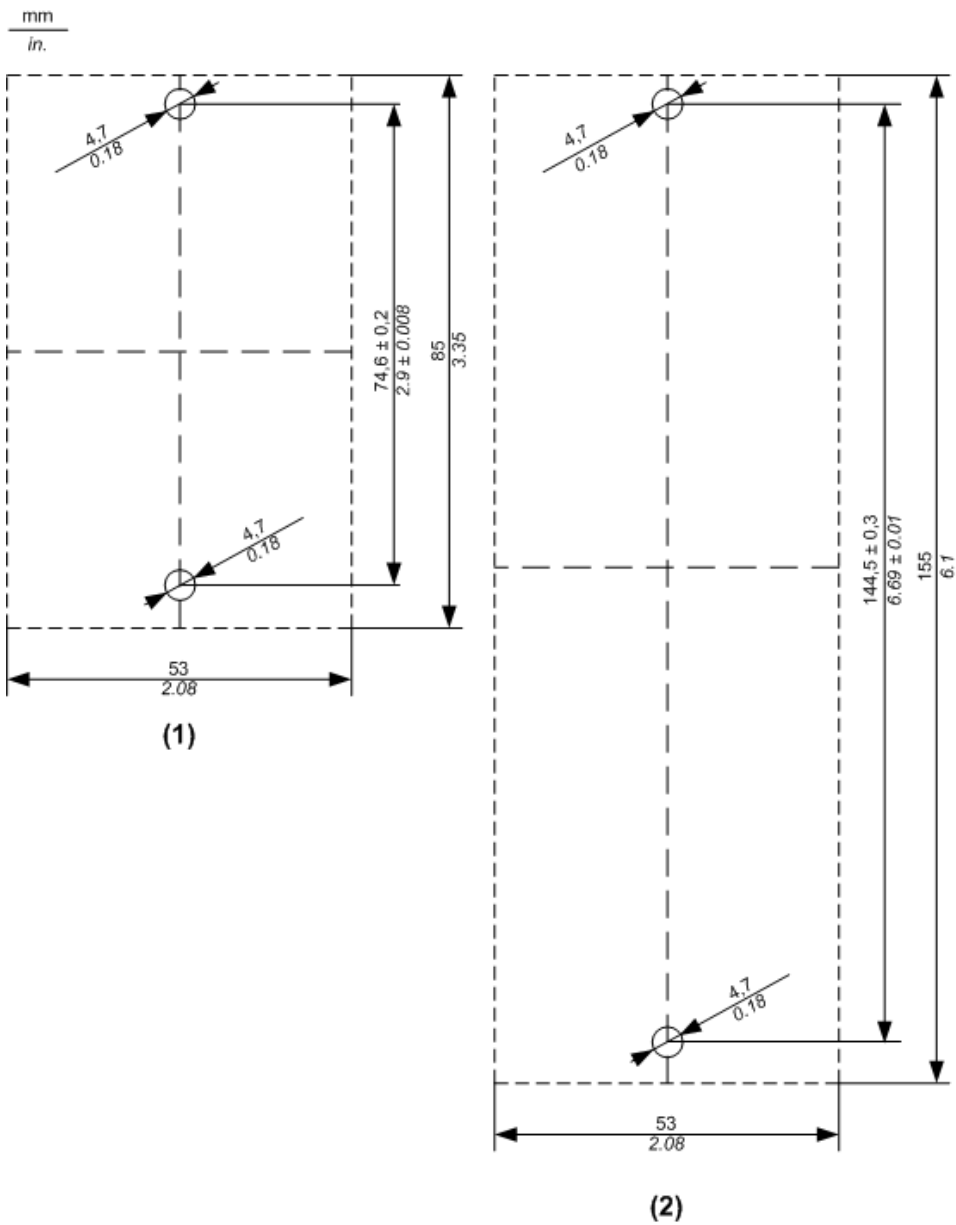

(1) Size 1

(2) Size 2

The thickness of the base plate should be taken into consideration when defining the screw length.

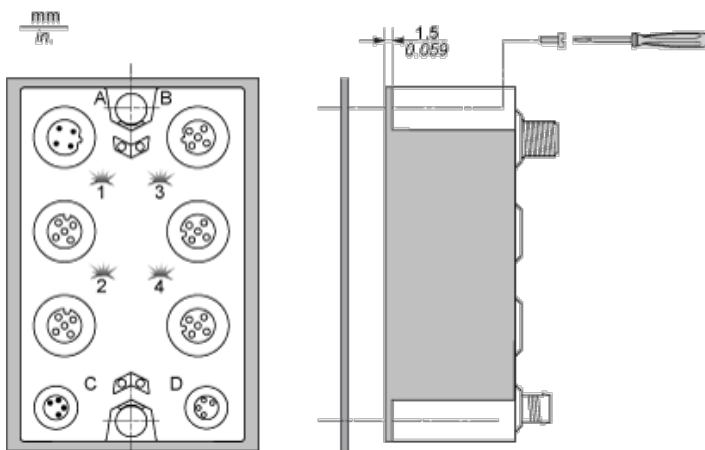

NOTE: Maximum torque to fasten the required M4 screws is 0.6 N.m (5.3 lbf-in).

Wiring Diagram

Pin Assignments for I/O Connectors

Connection	Pin	Designation
------------	-----	-------------

	1	24 Vdc sensor supply
	2	DI: input signal channel 1
	3	0 Vdc
	4	DI: input signal channel 2
	5	N.C.

CANopen Pins and Connectors

Connector Assignments

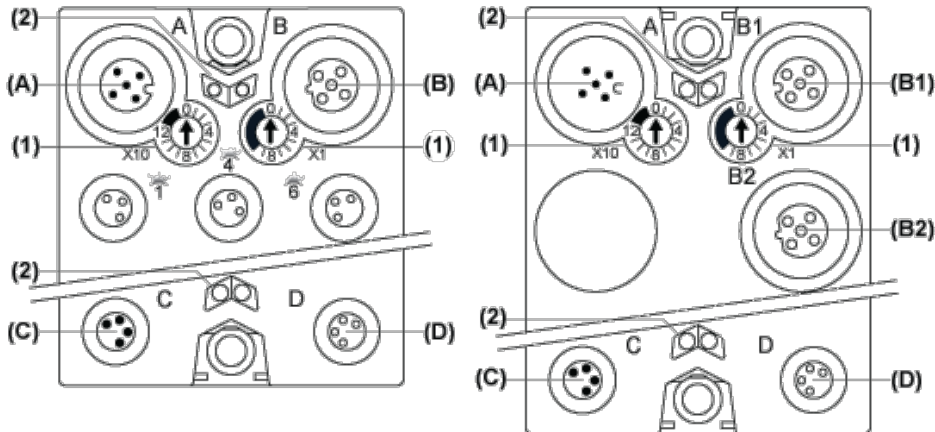

- (A) Field bus IN connector
- (B) TM7 bus OUT connector M12
and
(B2)
- (B1) CANopen bus OUT connector M12
- (C) 24 Vdc power IN connector
- (D) 24 Vdc power OUT connector
- (1) Address settings rotary switches
- (2) Status LEDs

Pin Assignments

Connectors	Pin	Designation
	1	CAN_SHLD
	2	(CAN_V+)
	3	CAN_GND
	4	CAN_H
	5	CAN_L
	1	TM7 V+
	2	TM7 Bus Data
	3	TM7 0V
	4	TM7 Bus $\overline{\text{Data}}$
	5	N.C.
	1	CAN_SHLD
	2	(CAN_V+)
	3	CAN_GND
	4	CAN_H
	5	CAN_L

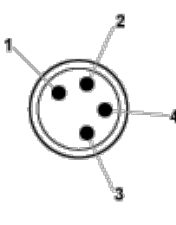
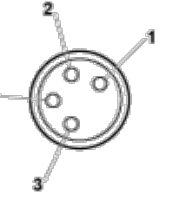
Connectors	Pin	Designation
	1	24 Vdc main power
	2	24 Vdc I/O power segment
	3	0 Vdc
	4	0 Vdc
	1	24 Vdc I/O power segment
	2	24 Vdc I/O power segment
	3	0 Vdc
	4	0 Vdc

Wiring the Power Supply

Connections	2 Power Supplies
24 Vdc main power that generates power for TM7 power bus	PS1
24 Vdc I/O power segment	PS2

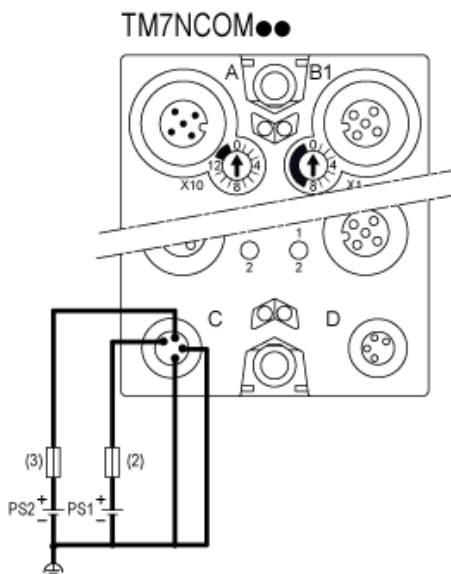

(2) External fuse, Type T slow-blow, 1 A, 250 V ¹

(3) External fuse, Type T slow-blow, 4 A max., 250 V

PS1 External isolated main power supply, 24 Vdc

PS2 External isolated I/O power supply, 24 Vdc

¹ Fuse limited to 1 A per PDB, maximum fuse limited to 5 A with maximum 4 PDB interconnected. If less than 4 PDBs size the fuse in accordance with the number of PDBs.

Switching Inductive Load Characteristics

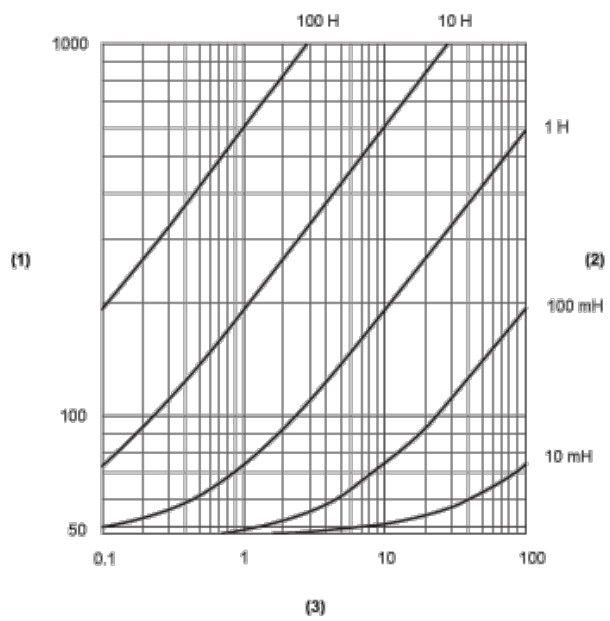

- (1) Load resistance in Ω
- (2) Load inductance in H
- (3) Max. operating cycles / second