

## TM7BDO8TAB

blok proširenja – TM7 – IP67 – 8 DO – 24 V DC – 2 A – konektor M8



### Glavno

Range of product	Modicon TM7
Product or component type	Discrete I/O expansion block
Range compatibility	Modicon LMC058 Modicon M258
Enclosure material	Plastic
Bus type	TM7 bus
[Ue] rated operational voltage	24 V DC
Input/output number	8
Input/output number of splitter box	8 O

### Komplementarno

Discrete output number	8 output(s) at <= 2 A with transistor protection
Discrete output voltage	24 V
Discrete output voltage type	DC
Sensor power supply	24 V, 500 mA for all channels with overload, short-circuit and reverse polarity protection
Electrical connection	1 male connector M8 - 4 ways for power IN 1 female connector M8 - 4 ways for power OUT 1 male connector M12 - B coding - 4 ways for bus IN 1 female connector M12 - B coding - 4 ways for bus OUT 1 female connector M8 - 3 ways for actuator
Local signalling	2 LEDs for bus diagnostic 2 LEDs for sensor power supply diagnostics
Operating position	Any position
Fixing mode	By 2 screws
Product weight	0.185 kg

### Okolina

standards	IEC 61131-2
product certifications	C-Tick CURus GOST-R ATEX II 3g EEx nA II T5
marking	CE
ambient air temperature for operation	-10...60 °C
ambient air temperature for storage	-25...85 °C
relative humidity	5...95 % without condensation or dripping water
pollution degree	2 conforming to IEC 60664
IP degree of protection	IP67 conforming to IEC 61131-2
operating altitude	0...2000 m
storage altitude	0...3000 m
vibration resistance	7.5 mm constant amplitude (f = 2...8 Hz) conforming to IEC 60721-3-5 Class 5M3 2 gn constant acceleration (f = 8...200 Hz) conforming to IEC 60721-3-5 Class 5M3 4 gn constant acceleration (f = 200...500 Hz) conforming to IEC 60721-3-5 Class 5M3
shock resistance	30 gn for 11 ms conforming to IEC 60721-3-5 Class 5M3
electromagnetic compatibility	Conducted and radiated emissions conforming to CISPR 11 Conducted RF disturbances conforming to EN/IEC 61000-4-6

Informacije dane u ovoj dokumentaciji sadrže opće opise i/ili tehničke karakteristike o performansama ovdje sadržanih proizvoda. Ova dokumentacija nije namijenjena kao zamjena za niti bi se trebala koristiti za određivanje prikladnosti ili pouzdanosti predmetnih proizvoda za konkretne korisničke primjene. Svaki takav korisnik ili integrator dužan je provesti odgovarajuću i potpunu analizu rizika, procjenu i ispitivanje proizvoda u odnosu na odgovarajuću specifičnu primjenu ili uporabu istog. Niti društvo Schneider Electric, Industries SAS niti bilo koje od njegovih povezanih poduzeća ili podružnica neće preuzeti obvezu ili snositi odgovornost za pogrešnu upotrebu ovdje sadržanih informacija.

Electrostatic discharge immunity test (level: 4 kV - on contact) conforming to EN/IEC 61000-4-2  
 Electrostatic discharge immunity test (level: 8 kV - in air) conforming to EN/IEC 61000-4-2  
 Susceptibility to electromagnetic fields (level: 1 V/m - 2...2.7 GHz) conforming to EN/IEC 61000-4-3  
 Susceptibility to electromagnetic fields (level: 10 V/m - 80...2000 MHz) conforming to EN/IEC 61000-4-3  
 Electrical fast transient/burst immunity test (level: 2 kV - power supply) conforming to EN/IEC 61000-4-4  
 Electrical fast transient/burst immunity test (level: 1 kV - input/output) conforming to EN/IEC 61000-4-4  
 Electrical fast transient/burst immunity test (level: 1 kV - shielded cable) conforming to EN/IEC 61000-4-4  
 1.2/50  $\mu$ s shock waves immunity test (level: 0.5 kV - power supply (common mode)) conforming to EN/IEC 61000-4-5  
 1.2/50  $\mu$ s shock waves immunity test (level: 1 kV - power supply (differential mode)) conforming to EN/IEC 61000-4-5  
 1.2/50  $\mu$ s shock waves immunity test (level: 0.5 kV - unshielded links (common mode)) conforming to EN/IEC 61000-4-5  
 1.2/50  $\mu$ s shock waves immunity test (level: 1 kV - unshielded links (differential mode)) conforming to EN/IEC 61000-4-5  
 1.2/50  $\mu$ s shock waves immunity test (level: 0.5 kV - shielded links (common mode)) conforming to EN/IEC 61000-4-5  
 1.2/50  $\mu$ s shock waves immunity test (level: 1 kV - shielded links (differential mode)) conforming to EN/IEC 61000-4-5

## Offer Sustainability

Green Premium product	Green Premium product
Compliant - since 1039 - Schneider Electric declaration of conformity	Compliant - since 1039 - Schneider Electric declaration of conformity
Reference not containing SVHC above the threshold	Reference not containing SVHC above the threshold
Available	Available
Available	Available

## Contractual warranty

Warranty period	18 months
-----------------	-----------

## Digital Output Block

### Description

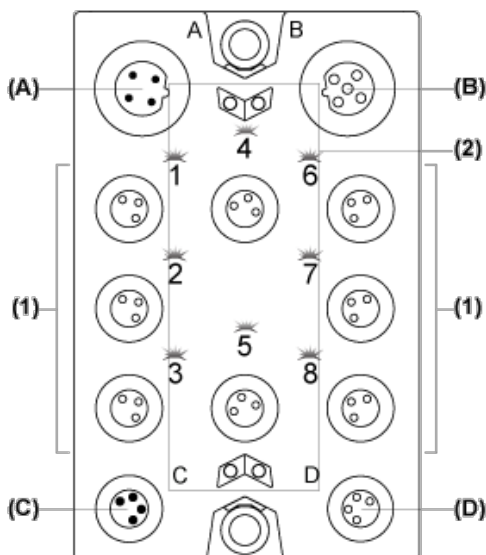

- (A) TM7 bus IN connector
- (B) TM7 bus OUT connector
- (C) 24 Vdc power IN connector
- (D) 24 Vdc power OUT connector
- (1) Output connectors
- (2) Status LEDs

### Connector and Channel Assignments

Output connectors	Channel type	Channels
1	Output	Q0
2	Output	Q1
3	Output	Q2
4	Output	Q3
5	Output	Q4
6	Output	Q5
7	Output	Q6
8	Output	Q7

## TM7 Block, Size 1

### Dimensions

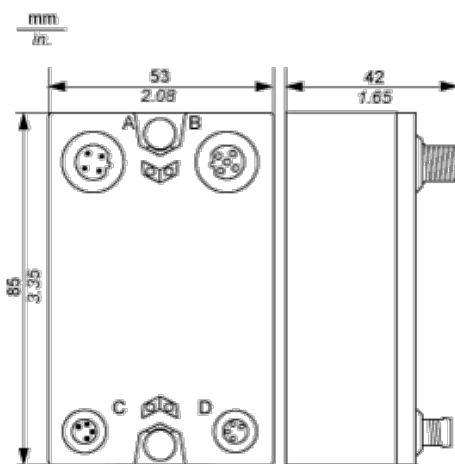

### Spacing Requirements

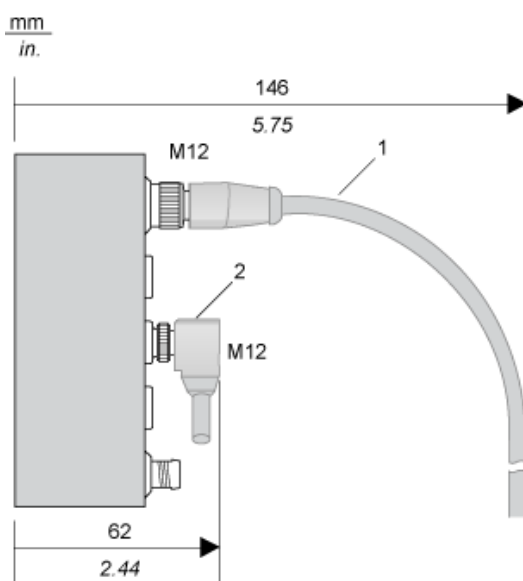

- 1 Straight cable
- 2 Elbowed cable

### Installation Guidelines

#### TM7 Block on an Aluminium Frame

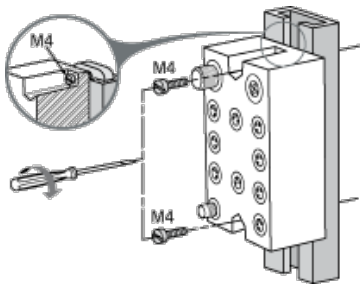

NOTE: Maximum torque to fasten the required M4 screws is 0.6 N.m (5.3 lbf-in).

**TM7 Block on a DIN Rail**

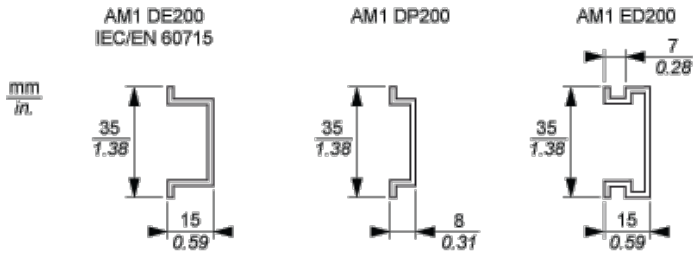

NOTE: Only size 1 (smallest) blocks can be installed on DIN rail with the TM7ACMP mounting plate.

**TM7 Block Directly on the Machine**

Drilling template of the block:

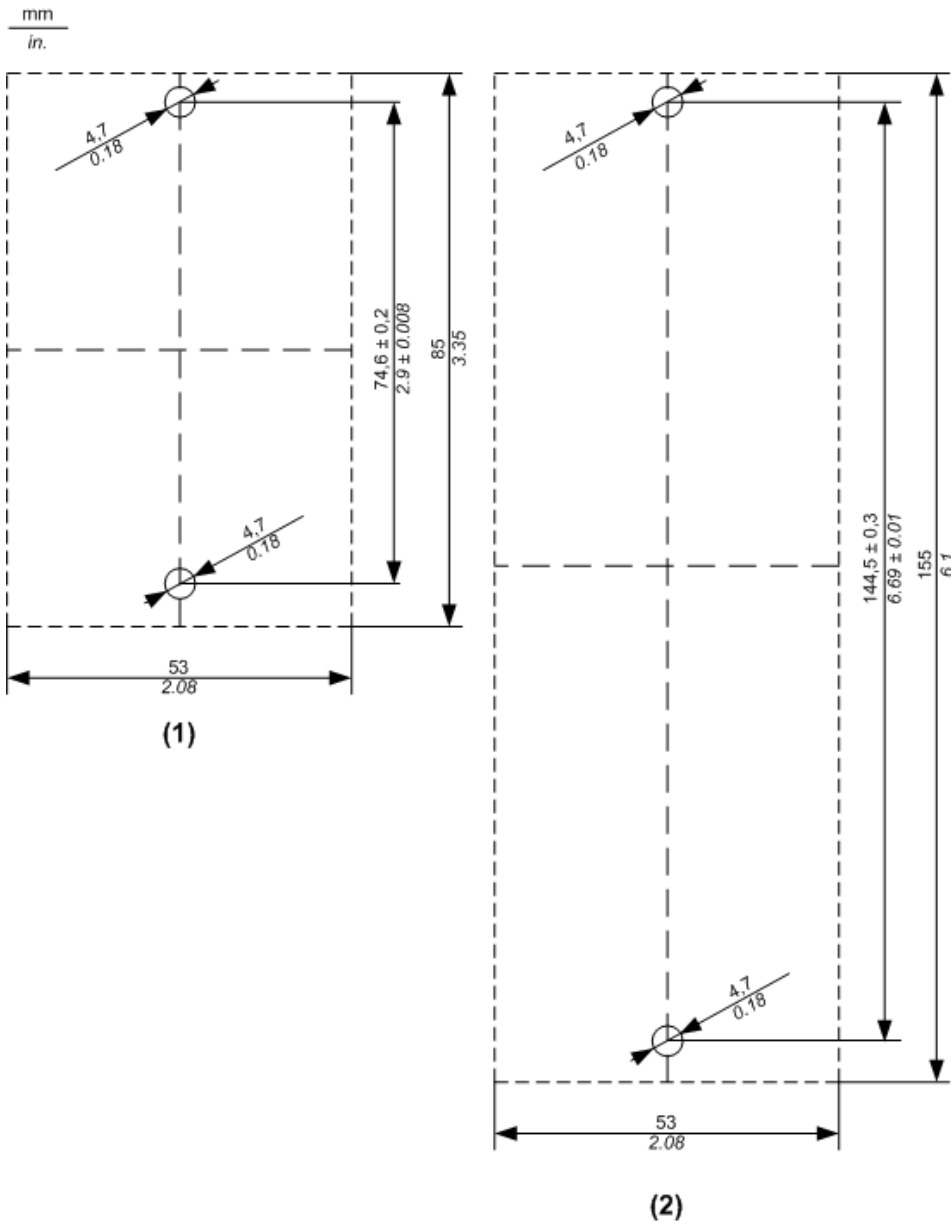

- (1) Size 1
- (2) Size 2

The thickness of the base plate should be taken into consideration when defining the screw length.

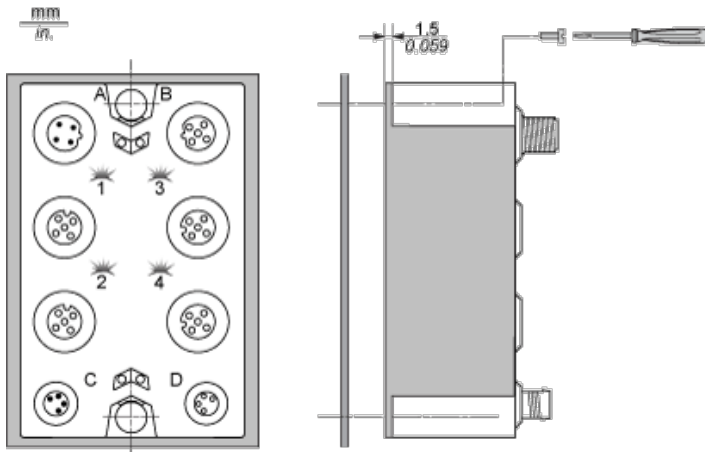

NOTE: Maximum torque to fasten the required M4 screws is 0.6 N.m (5.3 lbf-in).

## Wiring Diagram

### Pin Assignments for Output Connectors

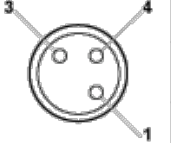
Connection	Pin	M8 Output
	1	24 Vdc actuator supply
	3	0 Vdc
	4	DO: output signal

## Wiring the Power Supply

When you provide power to a TM7 I/O block using the 24 VDC Power OUT connector of the preceding I/O block, both blocks occupy the same 24 Vdc I/O power segment. However, if you connect an external isolated power supply to the 24 Vdc Power IN connector of a TM7 I/O block, you establish a new 24 Vdc I/O power segment beginning with that I/O block.

I/O block wired with one external 24 Vdc power supply:

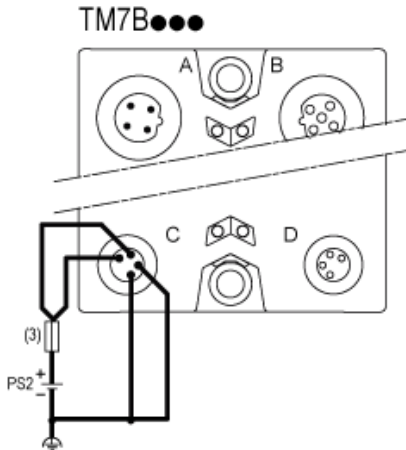

(3) External fuse, Type T slow-blow, 8 A max., 250 V

PS2 External isolated I/O power supply, 24 Vdc

## Switching Inductive Load Characteristics

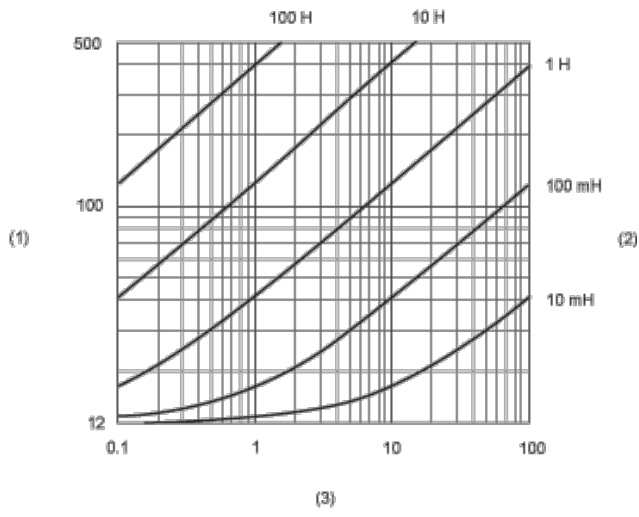

- (1) Load resistance in  $\Omega$
- (2) Load inductance in H
- (3) Max. operating cycles / second