



Glavno

Range of product	Modicon M241
Product or component type	Logic controller
[Us] rated supply voltage	24 V DC
Discrete input number	24 discrete input including 8 fast input conforming to IEC 61131-2 Type 1
Discrete output type	Transistor
Discrete output number	16 transistor including 4 fast output
Discrete output voltage	24 V DC for transistor output
Discrete output current	0.1 A with Q0...Q3 terminal(s) for fast output (PTO mode) 0.5 A with Q0...Q15 terminal(s) for transistor output

Komplementarno

Discrete I/O number	40
Number of I/O expansion module	7 (local I/O architecture) 14 (remote I/O architecture)
Supply voltage limits	20.4...28.8 V
Inrush current	50 A
Power consumption in W	32.6...40.4 W with max number of I/O expansion module
Discrete input logic	Sink or source
Discrete input voltage	24 V
Discrete input voltage type	DC
Voltage state 1 guaranteed	≥ 15 V for input
Voltage state 0 guaranteed	≤ 5 V for input
Discrete input current	7 mA for input 10.7 mA for fast input
Input impedance	4.7 k Ω for input 2.81 k Ω for fast input
Response time	≤ 2 μ s turn-on operation with I0...I17 terminal(s) for fast input ≤ 2 μ s turn-off operation with I0...I17 terminal(s) for fast input ≤ 2 μ s turn-on operation with Q0...Q3 terminal(s) for fast output ≤ 2 μ s turn-off operation with Q0...Q3 terminal(s) for fast output 50 μ s turn-on operation with I0...I15 terminal(s) for input 50 μ s turn-off operation with I0...I15 terminal(s) for input ≤ 34 μ s turn-on operation with Q0...Q15 terminal(s) for output ≤ 250 μ s turn-off operation with Q0...Q15 terminal(s) for output
Configurable filtering time	1 μ s for fast input 12 ms for fast input 0 ms for input 1 ms for input 4 ms for input 12 ms for input
Discrete output logic	Positive logic (source)
Output voltage limits	30 V DC
Current per output common	≤ 2 A
Output frequency	≤ 20 kHz for fast output (PWM mode) ≤ 100 kHz for fast output (PLS mode) ≤ 1 kHz for output
Accuracy	± 0.1 % at 0.02...0.1 kHz for fast output ± 1 % at 0.1...1 kHz for fast output
Leakage current	≤ 5 μ A for output
Voltage drop	≤ 1 V

Informacije dane u ovoj dokumentaciji sadrže opće opise i/ili tehničke karakteristike o performansama ovdje sadržanih proizvoda. Ova dokumentacija nije namijenjena kao zamjena za niti bi se trebala koristiti za određivanje prikladnosti ili pouzdanosti predmetnih proizvoda za konkretne korisničke primjene. Svaki takav korisnik ili integrator dužan je provesti odgovarajuću i potpunu analizu rizika, procjenu i ispitivanje proizvoda u odnosu na odgovarajuću specifičnu primjenu ili uporabu istog. Niti društvo Schneider Electric Industries SAS niti bilo koje od njegovih povezanih podružnica neće preuzeti obvezu ili snositi odgovornost za pogrešnu upotrebu ovdje sadržanih informacija.

Tungsten load	<= 2.4 W
Protection type	Short-circuit protection Short-circuit and overload protection with automatic reset Reverse polarity protection for fast output
Reset time	10 ms automatic reset output 12 s automatic reset fast output
Memory capacity	8 MB for program 64 MB for system memory RAM
Data backed up	128 MB built-in flash memory for backup of user programs
Data storage equipment	<= 16 GB SD card optional
Battery type	BR2032 lithium non-rechargeable, battery life: 4 yr
Backup time	2 years at 25 °C
Execution time for 1 KInstruction	0.3 ms for event and periodic task 0.7 ms for other instruction
Application structure	8 event tasks 4 cyclic master tasks 3 cyclic master tasks + 1 freewheeling task 8 external event tasks
Realtime clock	With
Clock drift	<= 60 s/month at 25 °C
Positioning functions	PTO function 4 channel(s) (positioning frequency: 100 kHz) PTO function 4 channel(s) for transistor output (positioning frequency: 1 kHz)
Counting input number	4 fast input (HSC mode) at 200 kHz 16 standard input at 1 kHz
Control signal type	A/B signal at 100 kHz for fast input (HSC mode) Pulse/direction signal at 200 kHz for fast input (HSC mode) Single phase signal at 200 kHz for fast input (HSC mode)
Integrated connection type	USB port with connector mini B USB 2.0 Ethernet with connector RJ45 Non isolated serial link "serial 1" with connector RJ45 and interface RS232/RS485 Non isolated serial link "serial 2" with connector removable screw terminal block and interface RS485
Supply	Serial link supply "serial 1" at 5 V, <= 200 mA
Transmission rate	1.2...115.2 kbit/s (115.2 kbit/s by default) for bus length of 15 m - communication protocol: RS485 1.2...115.2 kbit/s (115.2 kbit/s by default) for bus length of 3 m - communication protocol: RS232 480 Mbit/s for bus length of 3 m - communication protocol: USB 10/100 Mbit/s - communication protocol: Ethernet
Communication port protocol	Modbus non isolated serial link with master/slave method
Port Ethernet	1 - 10BASE-T/100BASE-TX port with copper cable support
Communication service	FDR Downloading IEC VAR ACCESS Monitoring NGVL Programming Updating firmware SMS notifications DHCP server (via TM4 Ethernet switch network module) DHCP client (embedded Ethernet port) SNMP client/server FTP client/server SQL client Modbus TCP client I/O scanner Ethernet/IP originator I/O scanner (embedded Ethernet port) Ethernet/IP target, Modbus TCP server and Modbus TCP slave Send and receive email from the controller based on TCP/UDP library Web server (WebVisu & XWeb system) OPC UA server DNS client
Local signalling	1 LED red for module error (ERR) 1 LED green for PWR 1 LED green for RUN 1 LED green for SD card access (SD) 1 LED red for BAT 1 LED green for SL1 1 LED green for SL2 1 LED per channel green for I/O state 1 LED red for I/O error (I/O)

	1 LED red for bus fault on TM4 (TM4) 1 LED green for Ethernet port activity
Electrical connection	Removable screw terminal block for inputs and outputs (pitch 5.08 mm) Removable screw terminal block for connecting the 24 V DC power supply (pitch 5.08 mm)
Cable distance between devices	Unshielded cable: ≤ 50 m for input Shielded cable: ≤ 10 m for fast input Unshielded cable: ≤ 50 m for output Shielded cable: ≤ 3 m for fast output
Insulation	500 V AC between fast input and internal logic Non-insulated between inputs 500 V AC between output and internal logic 500 V AC between fast output and internal logic Non-insulated between outputs 500 V AC between input and internal logic 500 V AC between output groups 500 V AC between supply and internal logic Non-insulated between supply and ground
Marking	CE
Surge withstand	1 kV for power lines (DC) in common mode conforming to EN/IEC 61000-4-5 1 kV for shielded cable in common mode conforming to EN/IEC 61000-4-5 0.5 kV for power lines (DC) in differential mode conforming to EN/IEC 61000-4-5 1 kV for relay output in differential mode conforming to EN/IEC 61000-4-5 1 kV for input in common mode conforming to EN/IEC 61000-4-5 1 kV for transistor output in common mode conforming to EN/IEC 61000-4-5
Web services	Web server
Maximum number of connections	8 connection(s) for Modbus server 8 connection(s) for SoMachine protocol 10 connection(s) for web server 4 connection(s) for FTP server 16 connection(s) for Ethernet/IP target 8 connection(s) for Modbus client
Number of slave	16 Ethernet/IP 64 Modbus TCP
Cycle time	10 ms 16 Ethernet/IP 64 ms 64 Modbus TCP
Mounting support	Top hat type TH35-15 rail conforming to IEC 60715 Top hat type TH35-7.5 rail conforming to IEC 60715 Plate or panel with fixing kit
Height	90 mm
Depth	95 mm
Width	190 mm
Product weight	0.62 kg

Okolina

standards	UL 508 CSA C22.2 No 142 ANSI/ISA 12-12-01 UL 1604 CSA C22.2 No 213 EN/IEC 61131-2: 2007 Marine specification (LR, ABS, DNV, GL)
product certifications	CSA CULus IACS E10 RCM
resistance to electrostatic discharge	4 kV on contact conforming to EN/IEC 61000-4-2 8 kV in air conforming to EN/IEC 61000-4-2
resistance to electromagnetic fields	10 V/m (80 MHz...1 GHz) conforming to EN/IEC 61000-4-3 3 V/m (1.4 GHz...2 GHz) conforming to EN/IEC 61000-4-3 1 V/m (2 GHz...3 GHz) conforming to EN/IEC 61000-4-3
resistance to fast transients	2 kV for power lines conforming to EN/IEC 61000-4-4 1 kV for Ethernet line conforming to EN/IEC 61000-4-4 1 kV for serial link conforming to EN/IEC 61000-4-4 1 kV for input conforming to EN/IEC 61000-4-4 1 kV for transistor output conforming to EN/IEC 61000-4-4
resistance to conducted disturbances	10 V (0.15...80 MHz) conforming to EN/IEC 61000-4-6 3 V (0.1...80 MHz) conforming to Marine specification (LR, ABS, DNV, GL) 10 V (spot frequency (2, 3, 4, 6.2, 8.2, 12.6, 16.5, 18.8, 22, 25 MHz)) conforming to

electromagnetic emission	Conducted emissions, test level: 120...69 dB μ V/m QP, condition of test: power lines (radio frequency: 10...150 kHz) conforming to EN/IEC 55011 Conducted emissions, test level: 63 dB μ V/m QP, condition of test: power lines (radio frequency: 1.5...30 MHz) conforming to EN/IEC 55011 Radiated emissions, test level: 40 dB μ V/m QP with class A (radio frequency: 30...230 MHz) conforming to EN/IEC 55011 Conducted emissions, test level: 79...63 dB μ V/m QP, condition of test: power lines (radio frequency: 150...1500 kHz) conforming to EN/IEC 55011 Radiated emissions, test level: 47 dB μ V/m QP with class A (radio frequency: 230...1000 MHz) conforming to EN/IEC 55011
immunity to microbreaks	10 ms
ambient air temperature for operation	-10...55 °C for horizontal installation -10...50 °C for vertical installation
ambient air temperature for storage	-25...70 °C
relative humidity	10...95 % without condensation in operation 10...95 % without condensation in storage
IP degree of protection	IP20 with protective cover in place
pollution degree	2
operating altitude	0...2000 m
storage altitude	0...3000 m
vibration resistance	3.5 mm (vibration frequency: 5...8.4 Hz) on symmetrical rail 3 gn (vibration frequency: 8.4...150 Hz) on symmetrical rail 3.5 mm (vibration frequency: 5...8.4 Hz) on panel mounting 3 gn (vibration frequency: 8.4...150 Hz) on panel mounting
shock resistance	15 gn for 11 ms

Offer Sustainability

Green Premium product	Green Premium product
Compliant - since 1330 - Schneider Electric declaration of conformity	Compliant - since 1330 - Schneider Electric declaration of conformity
Reference contains SVHC above the threshold - go to CaP for more details	Reference contains SVHC above the threshold
Available	Available
Available	Available

Dimensions

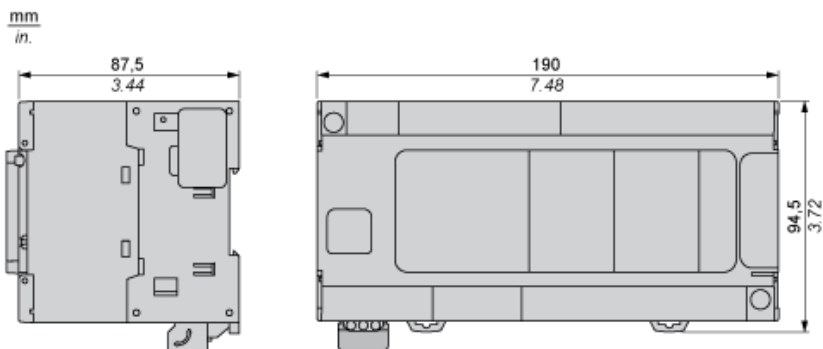

Clearance

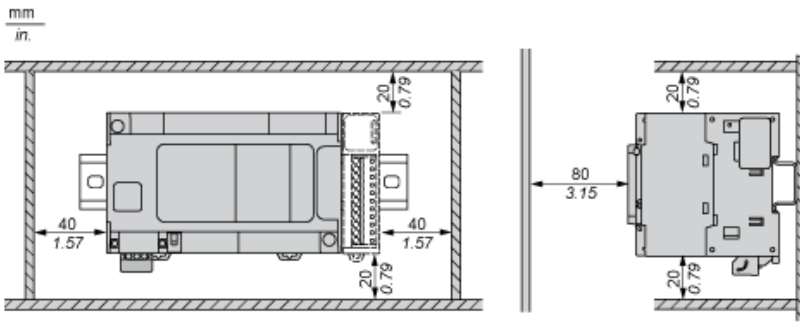

Mounting Position

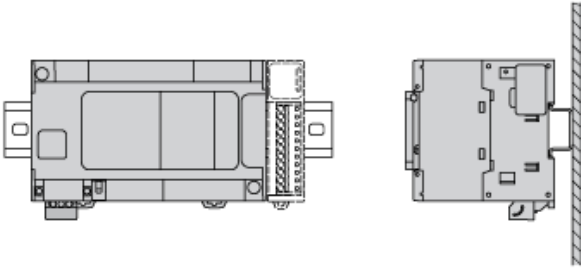

Acceptable Mounting

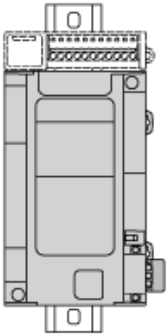

NOTE: Expansion modules must be mounted above the logic controller.

Incorrect Mounting

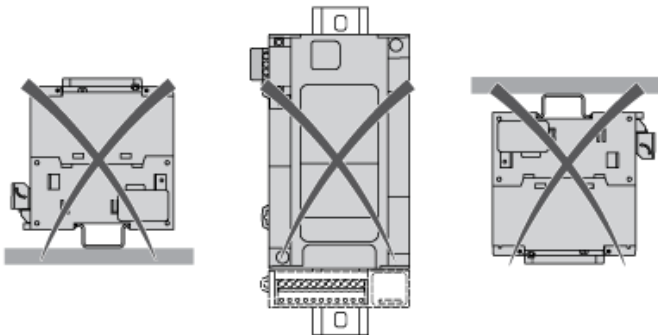

Direct Mounting On a Panel Surface

Mounting Hole Layout

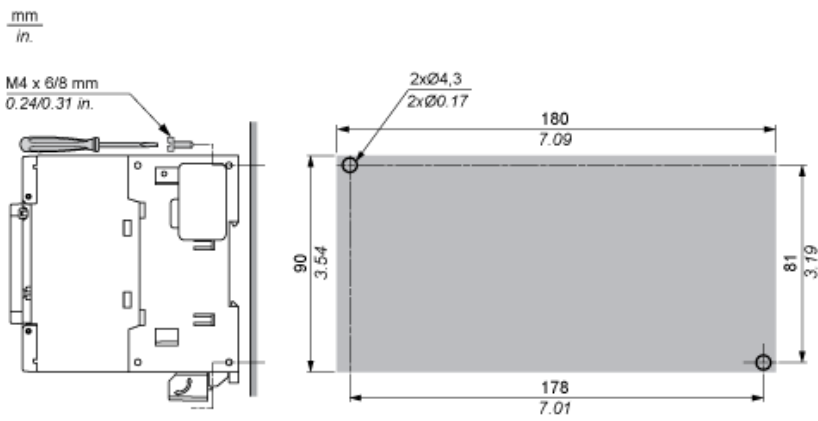

Digital Inputs

Wiring Diagram

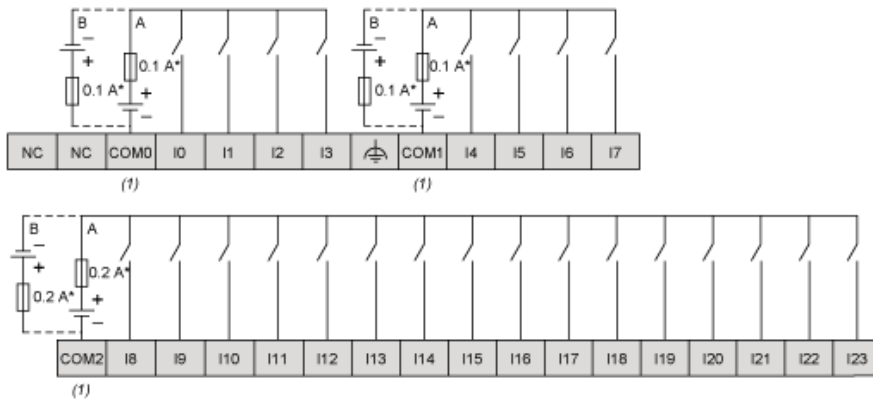

(*) : Type T fuse

(1) : The COM0, COM1 and COM2 terminals are not connected internally

(A) : Sink wiring (positive logic)

(B) : Source wiring (negative logic)

Fast Input Wiring (I0...I7)

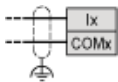

Fast Transistor Outputs

Wiring Diagram

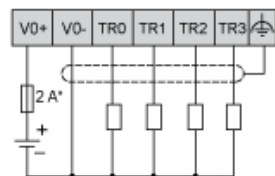

(*) : 2 A fast-blow fuse

Transistor Outputs

Wiring Diagram

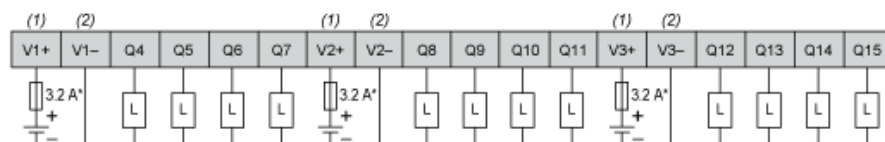

(*) : Type T fuse

(1) : The V1+, V2+ and V3+ terminals are not connected internally.

(2) : The V1-, V2- and V3- terminals are not connected internally.

USB Mini-B Connection

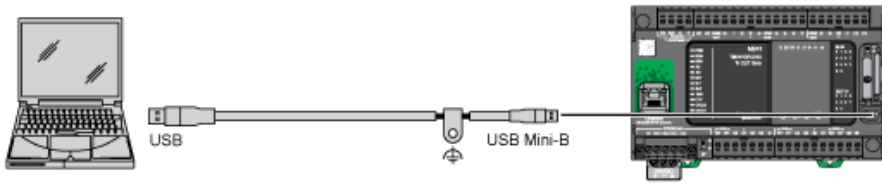

Ethernet Connection to a PC

