



Glavno

Range of product	Lexium 28
Product or component type	Motion servo drive
Device short name	LXM28A
Format of the drive	Compact housing
Line current	8.5 A, THDI of 155.5 % at 220 V, three phase 8.5 A, THDI of 176.3 % at 220 V, single phase

Komplementarno

Network number of phases	Single phase Three phase
[Us] rated supply voltage	220 V (- 10...15 %)for three phase 220 V (- 20...15 %)for single phase
Supply voltage limits	170...255 Vfor single phase 200...255 Vfor three phase
Supply frequency	50/60 Hz (- 5...5 %)
Network frequency	47.5...63 Hz
EMC filter	Without EMC filter
Continuous output current	7 A at 16 kHz
Output current 3s peak	21 A at 220 V
Continuous power	1000 W at 220 V
Nominal power	1 kW at 220 V, 16 kHz
Switching frequency	16 kHz
Overvoltage category	III
Leakage current	4.5 mA
Output voltage	<= power supply voltage
Electrical isolation	Between power and control
Type of cable	Shielded motor cable (temperature: 0...55 °C) copper
Electrical connection	Spring terminal, clamping capacity: 1.3...1.5 mm ² , AWG 16 (L1-L2) Spring terminal, clamping capacity: 1.3...1.5 mm ² , AWG 16 (R, S, T) Spring terminal, clamping capacity: 1.3...1.5 mm ² , AWG 16 (U, V, W, PE) Spring terminal, clamping capacity: 1.3...1.5 mm ² , AWG 16 (PA/+, PBe)
Discrete input number	8 programmable (CN1) 2 fast capture (CN1) 1 safety function STO (CN9) 1 pulse train input (PTI) (CN1)
Discrete input voltage	24 V DC (logic)
Discrete input logic	Positive or negative (CN1)
Discrete output number	5 logic output (CN1) at 12...24 V DC 1 pulse train output (PTO) (CN1)
Discrete output voltage	12...24 V DC
Discrete output logic	Positive or negative (CN1)
Analogue input number	2
Absolute accuracy error	0.1 %
Analogue input type	Voltage analog input (T_REF) Voltage analog input (V_REF), - 10...10 V input impedance: 10 kOhm, resolution: 14 bits
Control signal type	CN2: servo motor encoder feedback

Informacije dane u ovoj dokumentaciji sadrže opće opise i/ili tehničke karakteristike o performansama ovdje sadržanih proizvoda.
Ova dokumentacija nije namijenjena kao zamjena za niti bi se trebala koristiti za određivanje prikladnosti ili pouzdanosti predmetnih proizvoda za konkretne korisničke primjene.
Svaki takav korisnik ili integrator dužan je provesti odgovarajuću i potpunu analizu rizika, procjenu i ispitivanje specifičnu primjenu ili uporabu istog.
Niti društvo Schneider Electric Industries SAS niti bilo koje od njegovih povezanih poduzeća ili podružnica neće preuzeti obvezu ili snositi odgovornost za pogrešnu upotrebu ovdje sadržanih informacija.

Protection type	Against reverse polarity (inputs signal) Against short-circuits (outputs signal) Overcurrent (motor) Overvoltage (motor) Undervoltage (motor) Overheating (motor) Overload (motor) Overspeed (motor)
Safety function	STO (safe torque off), integrated
Safety level	SIL 2 conforming to IEC 61800-5-2: 2007 SIL 2 conforming to IEC 61508-1: 2010 PL d/category 3 conforming to EN/ISO 13849-1: 2008 SIL 2 conforming to EN/ISO 13849-1: 2009/AC SIL 2 conforming to EN 60204-1: 2006 SIL 2 conforming to EN 60204-1: 2009/A1 SIL 2 conforming to EN 60204-1: 2010/AC SIL 2 conforming to IEC 62061: 2012
Communication interface	CANmotion, integrated CANopen, integrated
Connector type	RJ45 (CN4) for CANopen, CANmotion
Method of access	Slave
Transmission rate	250 kbit/s for bus length of 100...250 m for CANopen, CANmotion 500 kbit/s for bus length of 4...100 m for CANopen, CANmotion 1 Mbit/s for bus length of ≤ 4 m for CANopen, CANmotion
Number of addresses	1...127 for CANopen, CANmotion
Physical interface	RS485 (Modbus Serial line slave)
Status LED	1 LED green for RUN 1 LED red for error 1 LED red for charge
Signalling function	Servo status and fault codes on five 7-segment display units
Marking	CE CSA CULus
Type of cooling	Integrated fan
Operating position	Vertical
Product compatibility	Servo motor BCH2 (130 mm, 1 motor stacks) at 1000 W Servo motor BCH2 (100 mm, 1 motor stacks) at 1000 W Servo motor BCH2 (130 mm, 2 motor stacks) at 900 W Servo motor BCH2 (130 mm, 4 motor stacks) at 850 W
Width	55 mm
Height	150 mm
Depth	170 mm
Product weight	1.2 kg
Output current 3s peak 2	21 A 220 V
Output current 3s peak 3	21 A 220 V

Okolina

electromagnetic compatibility standards	Conducted emission (test level:level 3, category C3) conforming to EN/IEC 61800-3 EN/IEC 61800-5-1
product certifications	CE CSA CULus
IP degree of protection	IP20
vibration resistance	3M4, amplitude = 3 mm (f = 9...200 Hz) conforming to IEC 60721-3-3
shock resistance	10 gn, type I conforming to IEC 60721-3-3
relative humidity	5...95 % without condensation
ambient air temperature for operation	0...55 °C
ambient air temperature for storage	-25...65 °C
operating altitude	≤ 1000 m (without derating) > 1000...2000 m (1 % per 100 m derating)

Offer Sustainability

Dimensions

Dimensions of Drive

mm
in

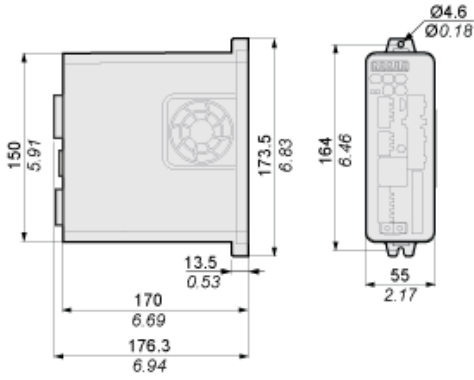

Mounting Clearance

Mounting Distances and Air Circulation

mm
in.

