

KSA1000AE4

Canalis – jedinica za napajanje s razdjelnikom – 1000 A

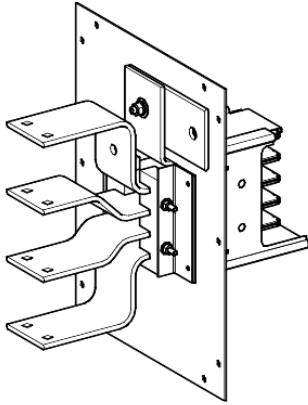

Glavno

Range of product	Canalis
Product name	KS
Product or component type	Flange feed unit
Material	Aluminium
Product compatibility	KS
[Ie] rated operational current	800 A 1000 A
Mounting location	Left Right
Colour	White: RAL 9001

Komplementarno

Protection type	Without protection
[Ue] rated operational voltage	230...690 V
Connections - terminals	Bar
Control type	Without
Number of circuits	1
Provided equipment	End cover
Mounting mode	By screws
Mounting support	Busbar
Standards	IEC 60439-2 IEC 61439-6
Width	290 mm
Depth	338 mm
Height	370 mm
Product weight	6.6 kg

Okolina

IP degree of protection	IP55 conforming to IEC 60529
IK degree of protection	IK08 conforming to IEC 62262

Offer Sustainability

Green Premium product	Green Premium product
Compliant - since 1009 - Schneider Electric declaration of conformity	Compliant - since 1009 - Schneider Electric declaration of conformity
Reference not containing SVHC above the threshold	Reference not containing SVHC above the threshold
Available	Available
Need no specific recycling operations	Need no specific recycling operations

Contractual warranty

Warranty period	18 months
-----------------	-----------

Informacije dane u ovoj dokumentaciji sadrže opće opise i/ili tehničke karakteristike o performansama ovdje sadržanih proizvoda. Ova dokumentacija nije namijenjena kao zamjena za niti bi se trebala koristiti za određivanje prikladnosti ili pouzdanosti predmetnih proizvoda za konkretne korisničke primjene. Svaki takav korisnik ili integrator dužan je provesti odgovarajuću i potpunu analizu rizika, procjenu i ispitivanje proizvoda u odnosu na odgovarajuću specifičnu primjenu ili uporabu istog. Niti društvo Schneider Electric Industries SAS niti bilo koje od njegovih povezanih poduzeća ili podružnica neće preuzeti obvezu ili snositi odgovornost za pogrešnu upotrebu sadržanih informacija.

