

GV7RE100

TeSys GV7 – prekidač – 3P – AC-3 – 60...100 A – termomagnetski



Glavno

Range	TeSys
Product name	TeSys GV7
Device short name	GV7R
Product or component type	Circuit breaker
Device application	Motor
Poles description	3P
Network type	AC
Utilisation category	AC-3 conforming to IEC 60947-4-1
Network frequency	50/60 Hz conforming to IEC 60947-4-1
Breaking capacity	8 kA Icu at 660/690 V AC 50/60 Hz conforming to IEC 60947-2 25 kA Icu at 500 V AC 50/60 Hz conforming to IEC 60947-2 35 kA Icu at 440 V AC 50/60 Hz conforming to IEC 60947-2 36 kA Icu at 380/415 V AC 50/60 Hz conforming to IEC 60947-2 85 kA Icu at 220/240 V AC 50/60 Hz conforming to IEC 60947-2
[Ics] rated service short-circuit breaking capacity	100 % at 440 V AC 50/60 Hz conforming to IEC 60947-2 50 % at 500 V AC 50/60 Hz conforming to IEC 60947-2 100 % at 220/240 V AC 50/60 Hz conforming to IEC 60947-2 100 % at 380/415 V AC 50/60 Hz conforming to IEC 60947-2 50 % at 660/690 V AC 50/60 Hz conforming to IEC 60947-2
Trip unit rating	60...100 A
Trip unit technology	Thermal-magnetic

Komplementarno

Mounting mode	By clips By screws
Mounting support	Flush Panel mounting Rail Kit for fixing the switchgear
Mounting position	Vertical
Motor power kW	45 kW at 400...415 V AC 50/60 Hz 75 kW at 660...690 V AC 50/60 Hz
Control type	Rocker lever
[Ue] rated operational voltage	690 V AC 50/60 Hz conforming to IEC 60947-2
[Ui] rated insulation voltage	750 V AC 50/60 Hz conforming to IEC 60947-2
[Ith] conventional free air thermal current	100 A conforming to IEC 60947-4-1
[Uimp] rated impulse withstand voltage	8 kV conforming to IEC 60947-2
Power dissipation	5 W
Power dissipation per pole	5 W
Mechanical durability	50000 cycles
Electrical durability	30000 cyclesfor AC-3 at 440 V In 50000 cyclesfor AC-3 at 440 V In/2
Operating rate	25 cyc/h

Informacije dane u ovoj dokumentaciji sadrže opće i/ili tehničke karakteristike o performansama ovdje sadržanih proizvoda. Ova dokumentacija nije namijenjena kao zamjena za niti bi se trebala koristiti za određivanje prikladnosti ili pouzdanosti predmetnih proizvoda za konkretne korisničke primjene. Svaki takav korisnik ili integrator dužan je provesti odgovarajuću i potpunu analizu rizika, procjenu i ispitivanje proizvoda u odnosu na odgovarajuću specifičnu primjenu ili uporabu istog. Niti društvo Schneider Electric, Industries SAS niti bilo koje od njegovih povezanih poduzeća ili podružnica neće preuzeti obvezu ili snositi odgovornost za pogrešku u potrošnji ovdje sadržanih informacija.

Rated duty	Continuous conforming to IEC 60947-4-1
Connection pitch	35 mm without spreaders 45 mm with spreaders
Connections - terminals	Screw Bars Cable with lug - external diameter : 10 mm Bare cable connectors 1.5...95 mm ²
Tightening torque	10 N.m - on screw - screw M6 15 N.m - on bare cable connectors- cable 1.5...95 mm ²
Mechanical robustness	Vibrations 2.5 Gn, 0...25 Hz conforming to IEC 60068-2-6 Shocks 15 Gn for 11 ms conforming to IEC 60068-2-27
Suitability for isolation	Yes conforming to IEC 60947-1
Phase failure sensitivity	Yes conforming to IEC 60947-4-1 § 7-2-1-5-2
Height	125 mm
Width	105 mm
Depth	111 mm
Product weight	2.04 kg

Okolina

standards	EN/IEC 60947-1 EN/IEC 60947-2 EN/IEC 60947-4-1 NF C 63-120 NF C 63-650 NF C 79-130 VDE 0113 VDE 0660
product certifications	DNV UL
protective treatment	TC
IP degree of protection	IP405 with terminal shrouds conforming to IEC 60529
pollution degree	3
ambient air temperature for operation	-25...70 °C
ambient air temperature for storage	-55...95 °C
fire resistance	960 °C conforming to IEC 60695-2-1
operating altitude	2000 m

Offer Sustainability

Not Green Premium product	Not Green Premium product
Will not be Compliant	Will not be Compliant
Reference not containing SVHC above the threshold	Reference not containing SVHC above the threshold
Available	Available

Contractual warranty

Warranty period	18 months
-----------------	-----------

Current Limitation on Short-Circuit (3-Phase 400/415 V)

Dynamic Stress

$I_{peak} = f$ (prospective I_{sc})

For GV7RE only

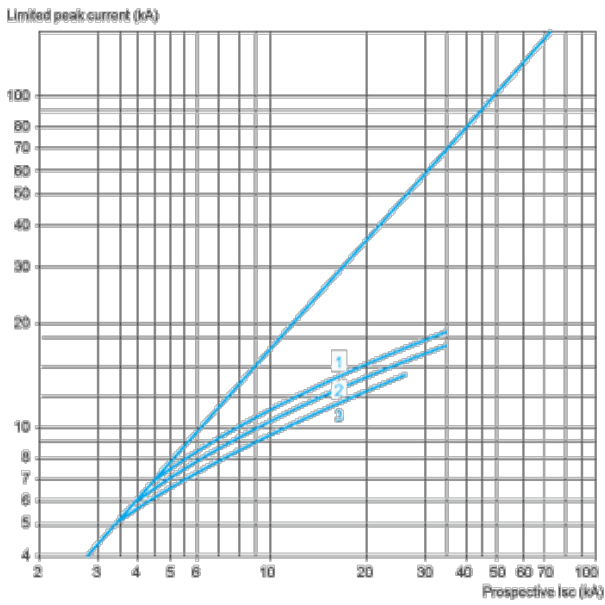

- 1 GV7RE220
- 2 GV7RE150
- 3 GV7RE100

Thermal Limit (3-Phase 400/415 V)

Thermal Limit

Sum of $I^2dt = f$ (prospective Isc)

For GV7RE only

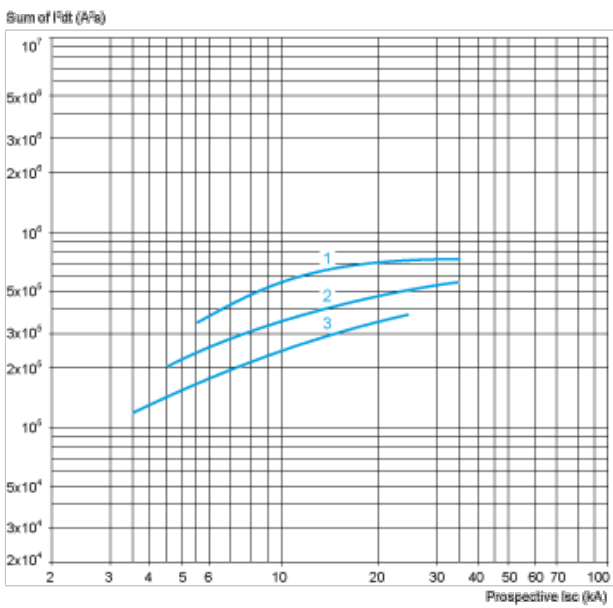

- 1 GV7RE220
- 2 GV7RE150
- 3 GV7RE100

Current Limitation on Short-Circuit (3-Phase 690 V)

Dynamic Stress

$I_{peak} = f$ (prospective Isc)

For GV7RE only

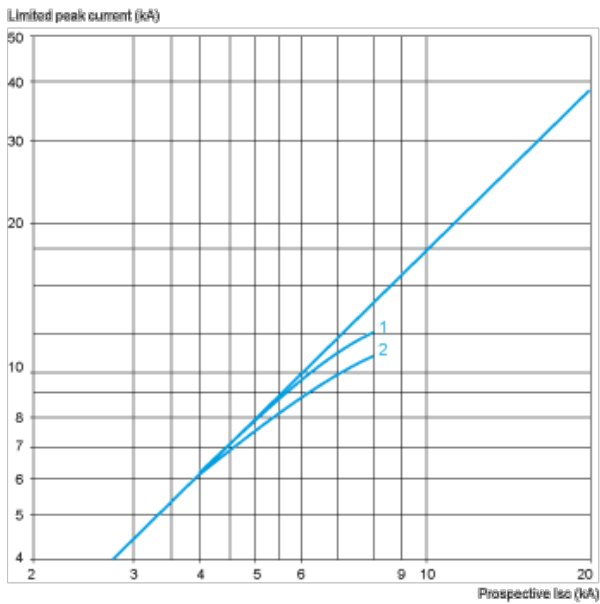

- 1 GV7RE220
- 2 GV7RE150 and GV7RE100

Thermal Limit on Short-Circuit (3-Phase 690 V)

Thermal Limit

Sum of $I^2dt = f$ (prospective Isc)

For GV7RE only

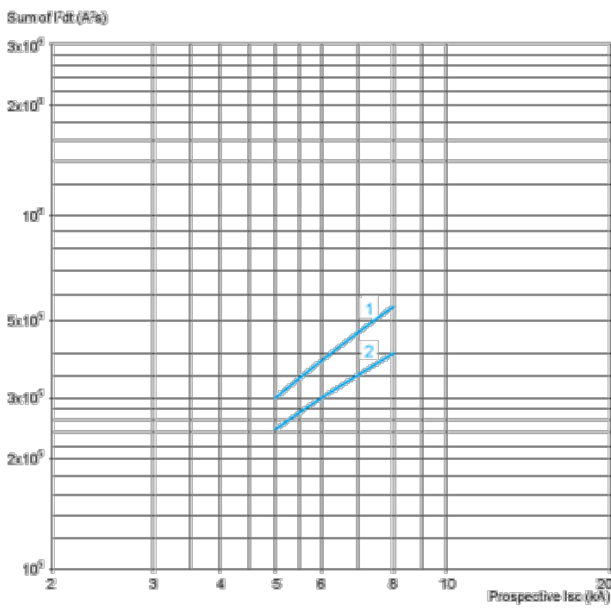

- 1 GV7RE220
- 2 GV7RE150 and GV7RE100

GV7R

Dimensions

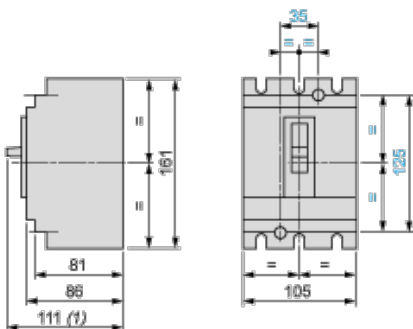

(1) 126 for GV7R_220.

Minimum Electrical Clearance

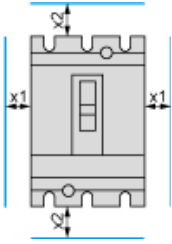

		x1	x2
Painted or insulated metal plate, insulation or insulated bar		0	30
Bare metal plate	$U \leq 440 \text{ V}$	5	35
	$440 \text{ V} < U < 600 \text{ V}$	10	35
	$U \geq 600 \text{ V}$	20	35

GV7R

Panel Mounting

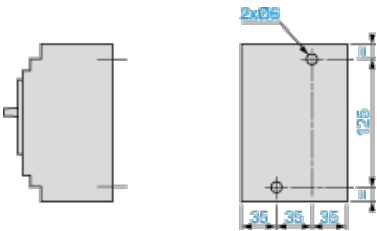

Mounting on 2 Mounting Rails DZ5 MB201

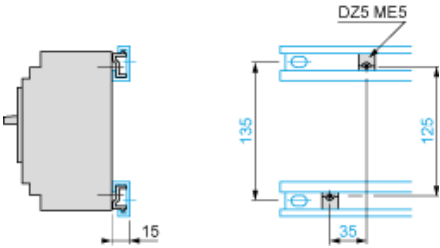

Flush-Mounting

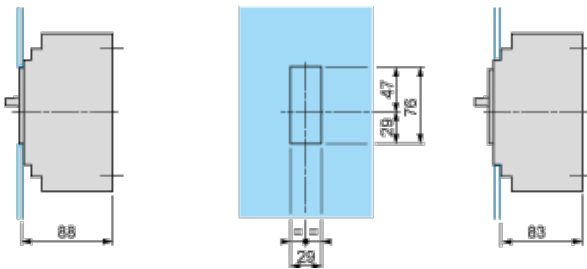

1 circuit breaker GV7R

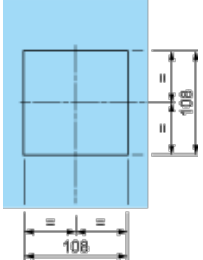

n circuit breakers GV7R side by side

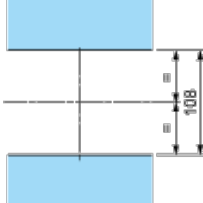

Connection

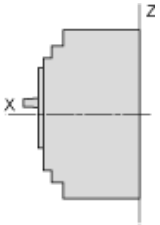

Smooth terminals

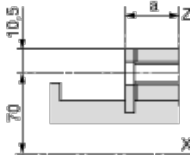

	a
GV7R _{40...R} 150	19.5
GV7R ₂₂₀	21.5

Connectors

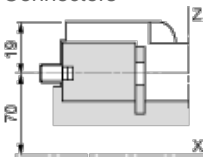

Motor Circuit Breakers

GV7 R

