

03074

montažna ploča za vertikalnu zakretnu ručicu
NSX/CVS/vigi 630, fiksna izvedba

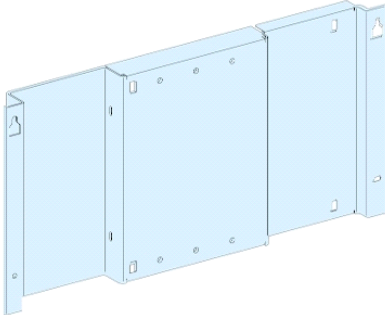

Glavno

Range	Prisma
Range compatibility	Prisma G
Product or component type	Mounting plate
Accessory / separate part category	Installation accessory
Installed device	Compact: fixed NSX400 without earth leakage protection - control: direct front rotary handle - vertical installation Compact: fixed NSX630 without earth leakage protection - control: direct front rotary handle - vertical installation Easypact: fixed CVS400 without earth leakage protection - control: direct front rotary handle - vertical installation Easypact: fixed CVS630 without earth leakage protection - control: direct front rotary handle - vertical installation Compact: fixed NSX400 with earth leakage protection - control: direct front rotary handle - vertical installation Compact: fixed NSX630 with earth leakage protection - control: direct front rotary handle - vertical installation Easypact: fixed CVS400 with earth leakage protection - control: direct front rotary handle - vertical installation Easypact: fixed CVS630 with earth leakage protection - control: direct front rotary handle - vertical installation
Poles description	1 x 3P: fixed: NSX400 vertical installation 1 x 3P: fixed: NSX630 vertical installation 1 x 3P: fixed: CVS400 vertical installation 1 x 3P: fixed: CVS630 vertical installation 1 x 4P: fixed: NSX400 vertical installation 1 x 4P: fixed: NSX630 vertical installation 1 x 4P: fixed: CVS400 vertical installation 1 x 4P: fixed: CVS630 vertical installation

Komplementarno

Enclosure/cubicle description	Floor-standing enclosure - width 600 mm Wall-mounted enclosure - width 600 mm
Number of vertical modules [50 mm]	15 module(s) : CVS400 without earth leakage protection , direct with long terminal shield in 600 mm Wide floor-standing enclosure (cable coming from top or bottom of enclosure) 15 module(s) : CVS400 without earth leakage protection , direct with long terminal shield in 600 mm Wide wall-mounted enclosure (cable coming from top or bottom of enclosure) 15 module(s) : CVS630 without earth leakage protection , direct with long terminal shield in 600 mm Wide floor-standing enclosure (cable coming from top or bottom of enclosure) 15 module(s) : CVS630 without earth leakage protection , direct with long terminal shield in 600 mm Wide wall-mounted enclosure (cable coming from top or bottom of enclosure) 15 module(s) : NSX400 without earth leakage protection , direct with long terminal shield in 600 mm Wide floor-standing enclosure (cable coming from top or bottom of enclosure) 15 module(s) : NSX400 without earth leakage protection , direct with long terminal shield in 600 mm Wide wall-mounted enclosure (cable coming from top or bottom of enclosure) 15 module(s) : NSX630 without earth leakage protection , direct with long terminal

Informacije dane u ovoj dokumentaciji sadrže opće opise i/ili tehničke karakteristike o performansama ovdje sadržanih proizvoda.
Ova dokumentacija nije namijenjena kao zamjena za niti bi se trebala koristiti za određivanje prikladnosti ili pouzdanosti predmetnih proizvoda za konkretne korisničke primjene.
Svaki takav korisnik ili integrator dužan je provesti odgovarajuću i poipunu analizu rizika, procjenu i ispitivanje proizvoda u odnosu na odgovarajuću specifičnu primjenu ili uporabu istog.
Niti društvo Schneider Electric, Industries SAS niti bilo koje od njegovih povezanih podružnica neće preuzeti obvezu ili snositi odgovornost za pogrešnu upotrebu ovdje sadržanih informacija.

shield in 600 mm Wide floor-standing enclosure (cable coming from top or bottom of enclosure)
 15 module(s) : NSX630 without earth leakage protection , direct with long terminal shield in 600 mm Wide wall-mounted enclosure (cable coming from top or bottom of enclosure)
 18 module(s) : CVS400 with earth leakage protection , direct with long terminal shield in 600 mm Wide floor-standing enclosure (cable coming from top or bottom of enclosure)
 18 module(s) : CVS400 with earth leakage protection , direct with long terminal shield in 600 mm Wide wall-mounted enclosure (cable coming from top or bottom of enclosure)
 18 module(s) : CVS630 with earth leakage protection , direct with long terminal shield in 600 mm Wide floor-standing enclosure (cable coming from top or bottom of enclosure)
 18 module(s) : CVS630 with earth leakage protection , direct with long terminal shield in 600 mm Wide wall-mounted enclosure (cable coming from top or bottom of enclosure)
 18 module(s) : NSX400 with earth leakage protection , direct with long terminal shield in 600 mm Wide floor-standing enclosure (cable coming from top or bottom of enclosure)
 18 module(s) : NSX400 with earth leakage protection , direct with long terminal shield in 600 mm Wide wall-mounted enclosure (cable coming from top or bottom of enclosure)
 18 module(s) : NSX630 with earth leakage protection , direct with long terminal shield in 600 mm Wide floor-standing enclosure (cable coming from top or bottom of enclosure)
 18 module(s) : NSX630 with earth leakage protection , direct with long terminal shield in 600 mm Wide wall-mounted enclosure (cable coming from top or bottom of enclosure)

Condition of use	Need additional plate (1M high) when installation of device is in vertical
Height	500 mm
Product weight	2.24 kg
Surface finish	Matt Smooth
Protective treatment	Electrophoresis treatment and hot-polymerised polyester epoxy powder
Colour	White RAL 9001

Okolina

standards	IEC 61439-2
product certifications	ASEFA

Offer Sustainability

Green Premium product	Green Premium product
Compliant - since 0807 - Schneider Electric declaration of conformity	Compliant - since 0807 - Schneider Electric declaration of conformity
Reference not containing SVHC above the threshold	Reference not containing SVHC above the threshold
Available	Available
Need no specific recycling operations	Need no specific recycling operations

Contractual warranty

Warranty period	18 months
-----------------	-----------